

# ETEC

[www.etek-china.com](http://www.etek-china.com) ▾

## PRODUCT SELECTION GUIDE

*Always for your safety*



ZHEJIANG ETEK ELECTRICAL TECHNOLOGY CO.,LTD.

# ETEC



EKEC1 series AC EV Charging Station



OPEN THE GREEN ENERGY ERA



EKEC4 series AC EV Charging Station



## Naming rules

EK EC□ - □□□P□ - □

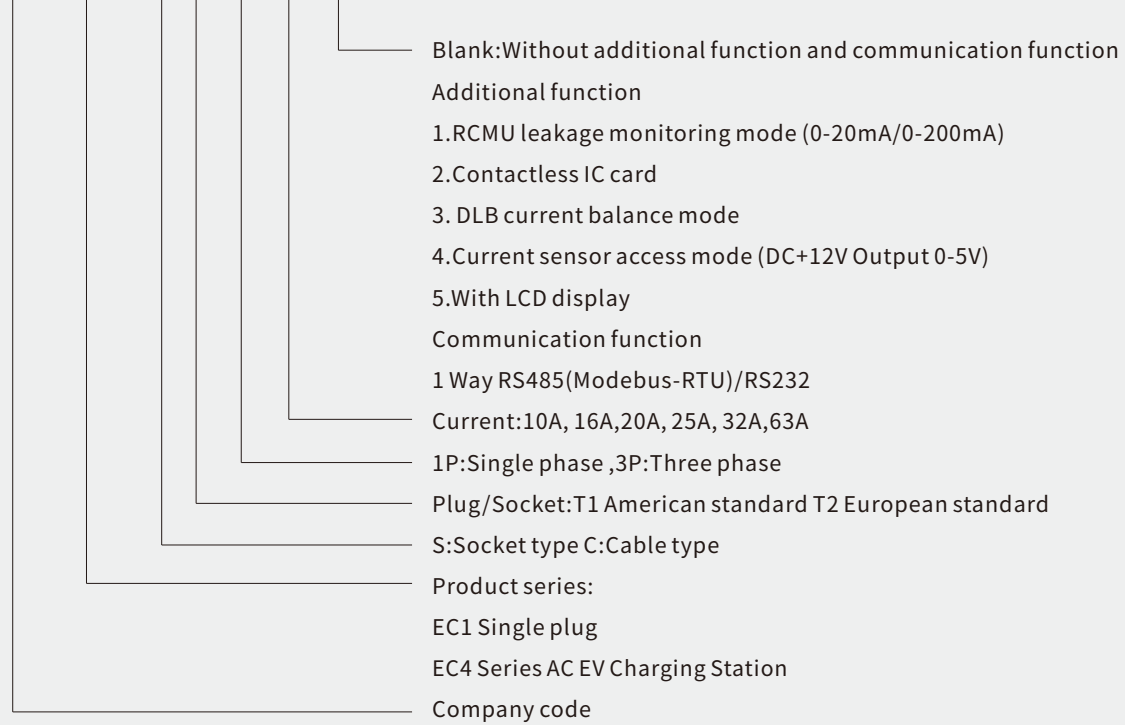

# EKEC1 Series AC EV Charging Station



Standard: IEC61851



## Technical data

Technical data	Model specification	Cable type		Socket type	
		EKEC1-C-T1/T2-1P	EKEC1-C-T1/T2-3P	EKEC1-S-T1/T2-1P	EKEC1-S-T1/T2-3P
Power mode		1P+N+PE	3P+N+PE	1P+N+PE	3P+N+PE
Operation voltage		AC230V±10% 50Hz	AC400V±10% 50Hz	AC230V±10% 50Hz	AC400V±10% 50Hz
Output current		10A、16A、20A、25A、32A/63A			
Output voltage		AC230V±10% 50Hz	AC400V±10% 50Hz	AC230V±10% 50Hz	AC400V±10% 50Hz
Output power		7.3KW/14.5KW	22KW/43.5KW	7.3KW/14.5KW	22KW/43.5KW
Cable length		5m	5m	-	-
Plug / socket standard		(American standard /European standard ) Type 1 /Type 2			
Additional function (Optional)		1.RCMU leakage monitoring mode (0-20mA/0-200mA) 2.Non-contact IC Card 3.DLB current balance mode 4.Current sensor access mode (DC+12V Output 0-5V) 5.With LCD display			
Communication function (optional)		1 way RS485(Modebus-RTU)/RS232			
Ambient temperature		-40°C +50°C			
Humidity		≤85%			
IP degree		IP55			
Cooling method		Natural cooling			
Installation method		Portable type /wall mounted type /Column type			
Weight					
Overall dimension		357*245*123	357*245*123	357*245*123	357*245*123
Installation dimension		180*280	180*280	180*280	180*280

## Overall installation drawing

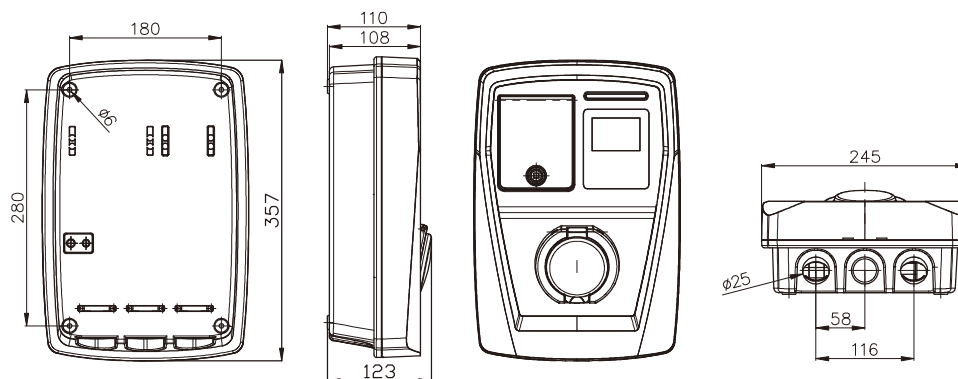

# EKEC4 Series AC EV Charging Station



Standard: IEC61851



## Technical data

Technical data	Model specification	Cable type		Socket type	
		EKEC4-C-T1/T2-1P	EKEC4-C-T1/T2-3P	EKEC4-S-T1/T2-1P	EKEC4-S-T1/T2-3P
Power mode		1P+N+PE	3P+N+PE	1P+N+PE	3P+N+PE
Operation voltage		AC230V±10% 50Hz	AC400V±10% 50Hz	AC230V±10% 50Hz	AC400V±10% 50Hz
Output current		10A、16A、20A、25A、32A/63A			
Output voltage		AC230V±10% 50Hz	AC400V±10% 50Hz	AC230V±10% 50Hz	AC400V±10% 50Hz
Output power		7.3KW/14.5KW	22KW/43.5KW	7.3KW/14.5KW	22KW/43.5KW
Cable length		5m	5m	-	-
Plug \ socket standard		(American standard /European standard ) Type 1 /Type 2			
Additional function (Optional)		1.RCMU leakage monitoring mode (0-20mA/0-200mA) 2.Non-contact IC Card 3.DLB current balance mode 4.Current sensor access mode (DC+12V Output 0-5V) 5.With LCD display			
Communication function (optional)		1 way RS485(Modebus-RTU)/RS232			
Ambient temperature		-40°C -+50°C			
Humidity		≤85%			
IP degree		Ip55			
Cooling method		Natural cooling			
Installation method		Portable type /wall mounted type /Column type			
Overall dimension		150*200*140	150*200*140	150*200*140	150*200*140
Installation dimension		128*178	128*178	128*128	128*128
Weight		2.6kg	2.9kg	1.4kg	1.5kg

## Overall installation drawing

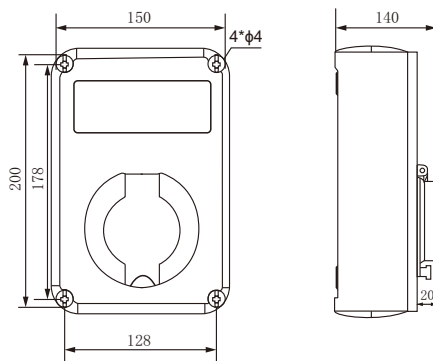

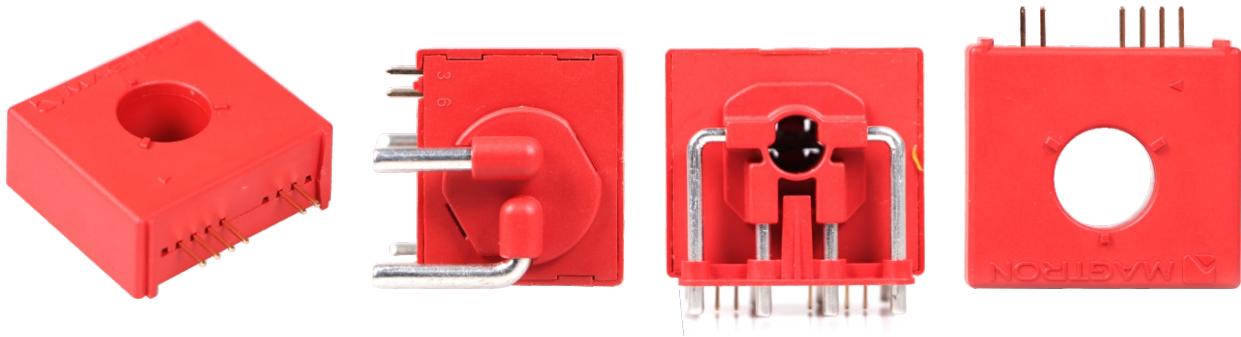

## RCMU Function

### RCMU Function brief outline

When the charging station is working, if there is a DC leakage current signal, the RCMU will immediately output a fault signal and cut off the output power within 300ms, ensuring the safety and reliability of personal and property. If the fault is eliminated, the charging station will automatically restart charging according to the program within 3S. Before charging, the RCMU module of the device will automatically carry out the accuracy and detection of the DC leakage current to ensure the safe and reliable operation of the device.

### RCMU Use

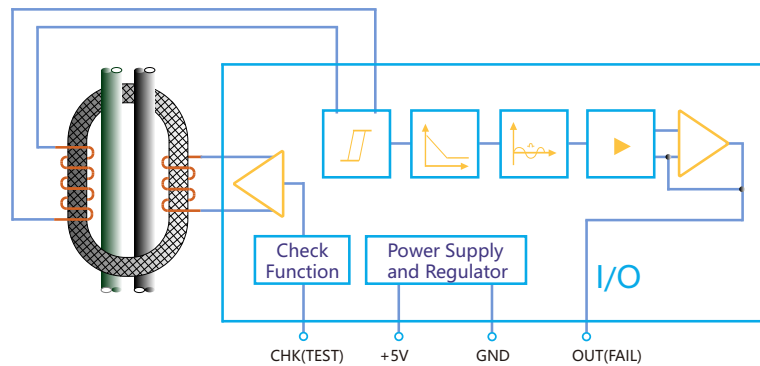

### RCMU101SM

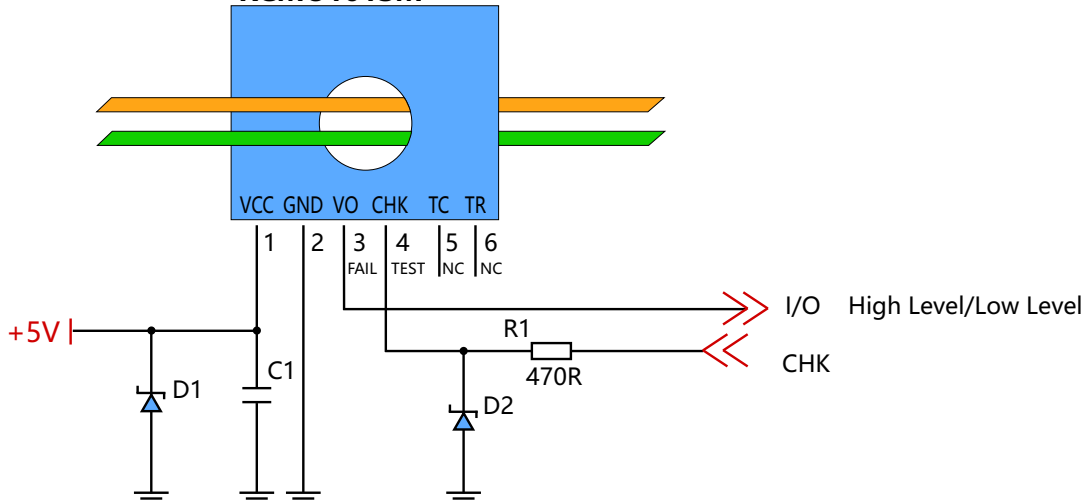

## RCMU Function

### RCMU Self-check function

When the main circuit is not working, the leakage current is 0, and Vout is at low level (0V) at this time .  
 (a) When the CHK PIN pin is set to high level (3.3-5V), Vout rises from low level to high voltage (Vcc) at this time.  
 (b) When the CHK PIN pin is set to low level (0.2v), the Vout generated at this time drops to low level (0V);  
 When the above (a) and (b) are completed, it is judged that the residual current sensor is functioning normally.  
 When the readme function is not working, you can add a 0 ohm resistor to the CHK PIN pin and ground it.

### Self test sequence diagram

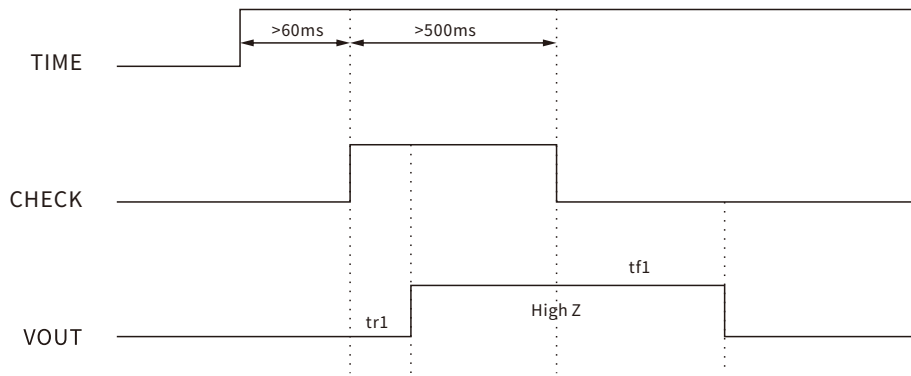

### Interrupt time according to IEC62752 & IEC 62955

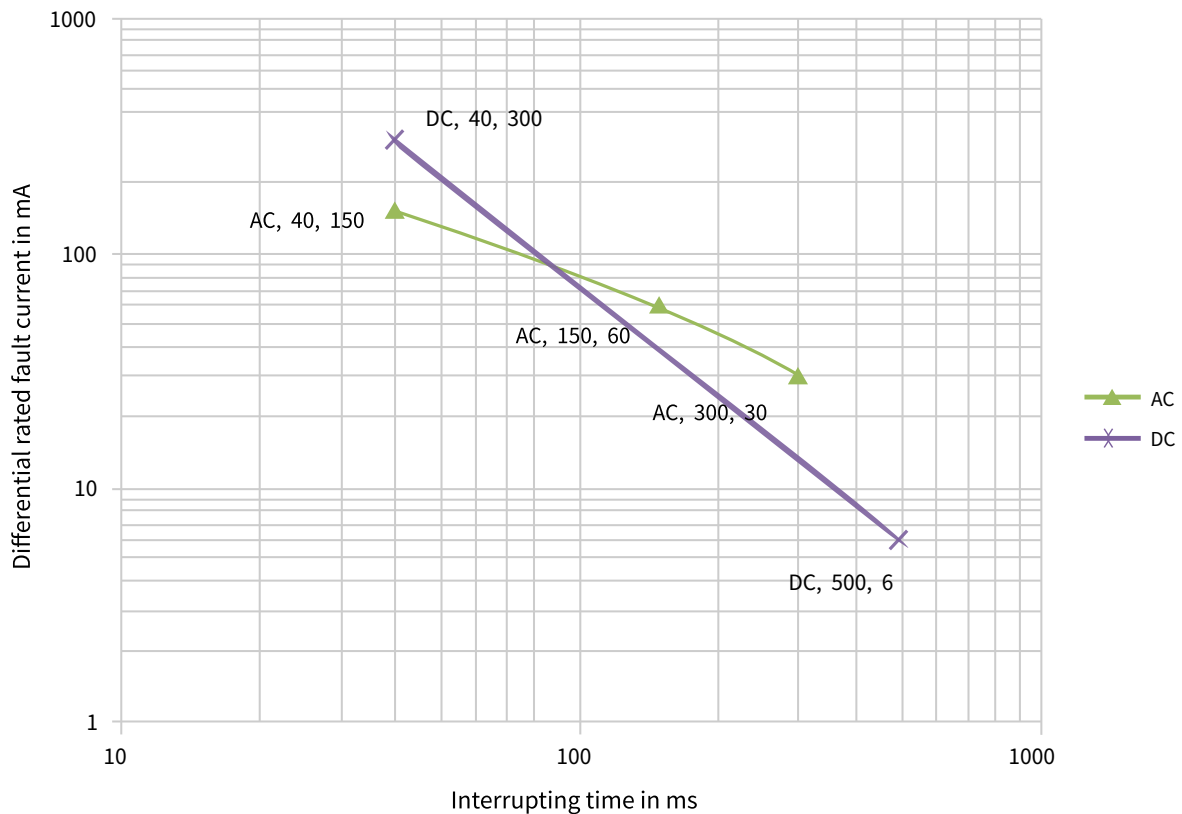

## RFID Function

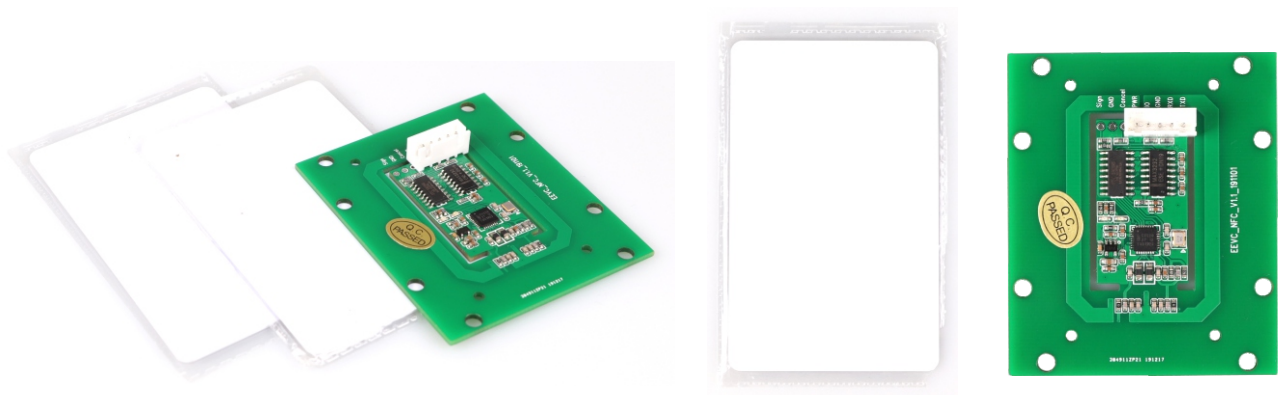

### Function Brief introduction

The charging station can be configured with contactless IC card swiping function, and charging can only be carried out through authorized IC card. If the IC card is lost, the internal dip switch can be used to set the IC card losing module. There are 3 IC cards which are authorized by the factory, unless specify that we can provide more IC cards.

## DLB function

### Function Brief introduction

This function is the automatic distribution of charging current, through an external current transformer (the output current is AC5A), the longest wiring length of the transformer is 100mm (2.5 square).

During the charging process, the charging station will monitor the online charging current in real time and make corresponding adjustments.

When it is detected that the current of the main circuit is greater than the set current, the charging station will reduce the charging current until the charging is stopped.

When it is detected that the current of the main circuit is less than the set current, the charging station will continue to increase the charging current until 32A or 63A.

In this state, the maximum charging current of the charging station is 32A and 63A.

While the charging current is uncertain, the current setting switch of the charging station becomes the transformation ratio setting switch of the current transformer. The transformation ratio of the external current transformer is set by software or factory setting. The factory default current transformer transformation ratio is 100A/5A.



## DLB Function

### DLB Function application legend

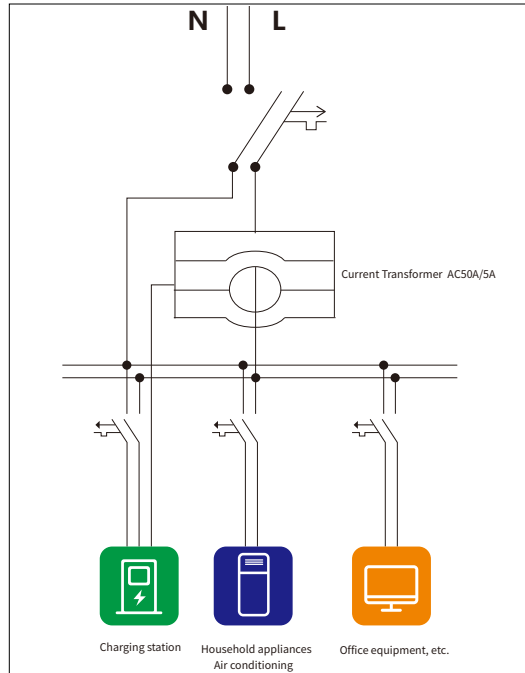

## Current Transformer access function

The charging station can provide an analog input function, the input analog is AC0-5A, which is used to display the current working current. When the detected working current is greater than the set current value, the charging station will reduce the charging current to the set current value. Thereby ensuring the safe and reliable operation of the charging station.

## LCD display function

The charging station can provide an analog input function, the input analog is AC0-1.0V, which is used to display the current working current. When the detected working current is greater than the set current value, the charging station will reduce the charging current to the set current value. Thereby ensuring the safe and reliable operation of the charging station.

### Display content

EKEC Series Charging Station	
Operation voltage:	220V
Set current:	32.0A
Output Current:	32.0A
Electricity consumption:	15.8KWH
Charging time:	1 h 01 min 01 s
Operation status:	Charging
Device status:	Normal
Communication status :	Connecting

The charging station with a LCD to display which can show the working status and charging related data , it is convenient and intuitive.

## Communication function

RS485 Communication description (Modbus-RTU model, Baud rate: 38400, fixed, address: 1-255 default: 255 (Broadcast address))

Register address number	Data description (power failure protection)	Read and write	Type of data	Defaults
100	(Device address number)	Read and write	16-bit integer	255
101	DLB maximum starting current	Read and write	16-bit integer	9000
102	DLB maximum current (100.00A)	Read and write	16-bit integer	10000
103	Reference current: DLB/current transformation ratio (100.00A)	Read and write	16-bit integer	10000
104	Reference current calibration value input	Read and write	16-bit integer	1270
105	Charging pile current transformation ratio 50-200A	Read and write	16-bit integer	
106	Charging pile current value correction 0-100.0A	Read and write	16-bit integer	
107	Charging pile voltage value correction 0-500.0V	Read and write	16-bit integer	
108	Charging pile power value correction 0-22000W	Read and write	16-bit integer	
109	Maximum output PWM duty cycle of charging pile	Read and write	16-bit integer	90%
110	RCMU function selection 0 disabled 1 enabled, other values are selected by DIP switch	Read and write	16-bit integer	3
111	RFID function selection 0 disabled 1 enabled, other values are selected by DIP switch	Read and write	16-bit integer	3
112	Lock function selection 0 disabled 1 enabled, other values are selected by DIP switch	Read and write	16-bit integer	3
113	Cable function version selection 0 disable 1 enable, other values are selected by DIP switch	Read and write	16-bit integer	3
114	DLB function selection 0 disable 1 enable, other values are selected by DIP switch	Read and write	16-bit integer	3
115	PID control parameter P of DLB	Read and write	16-bit integer	100
116	PID control parameters of DLB I	Read and write	16-bit integer	1
117	DLB PID control parameter D	Read and write	16-bit integer	100
118-119	Controller ID number up to 9 digits	Read and write	32-bit integer	
120-139	spare	Read and write		
140	Software version	Read only	16-bit integer	1002
141	Current working status: Corresponding status 0-13	Read only	16-bit integer	
142	PWM value of cable specification	Read only	16-bit integer	
143	RCMU status 00 Not selected 01 Normal operation 02 Self-check failed 03 There is leakage in the charging circuit	Read only	16-bit integer	
144	RFID status 00 not selected 01 IC card not operating 02 IC card closed 03 IC card open	Read only	16-bit integer	
145	Lock status 00 not selected 01 locked 02 unlocked 03 fault	Read only	16-bit integer	
146	The current current, the decimal place is determined by the value of the reference current	Read only	16-bit integer	
147	Current value of charging pile 0-200.0A	Read only	16-bit integer	
148	Current voltage value of charging pile 0-500.0V	Read only	16-bit integer	
149	Current power value of charging pile 0-22000W	Read only	16-bit integer	
150	Calibration value AD value of reference current	Read only	16-bit integer	
151	The PWM duty cycle corresponding to the current set by the rotary switch	Read only	16-bit integer	
152	Current output PWM duty cycle	Read only	16-bit integer	
153-160	spare	Read only	16-bit integer	

## Controller connection status

No.	State Code	LED Color	LED State	PE, CP, PP state	Controller state	Remark
0	K	Red	5Hz flashing	Power self detect failed	Fault--1#	Power self-check failed! Please turn the power back on!
1	A	Blue	1Hz flashing	CP disconnection	Ready	
2	I	Blue	2Hz flashing	Waiting for IC card	RFID Waiting	
3	B	Blue	Stabilization	CP connect to diode+2.7KΩ	Connected	
4	B	Blue	Stabilization	CP connect to diode+1.3KΩ	Connected	
5	C	Green	Green brightening	CP connect to diode+2.7KΩ parallel connect 1.3KΩ	Charging	
6	D	Red	Stabilization	CP connect to diode+2.7KΩ parallel connect 1.3KΩ parallel connect 270R Or CP connect to diode+270R Or CP connect to diode+270R parallel connect 2.7KΩ Or CP connect to diode+270R parallel connect 1.3KΩ	Fault--2#	Need Ventilation!
7	F	Red	1Hz flashing	CP line short circuit with PE line	Fault--3#	CP- PE short circuit! Please check the CP line
8	H	Red	5 Hz flashing	RCMU occurs residual current or self detect failed	Fault--4#	RCMU leakage or self-inspection failure
9	E	Red	2Hz flashing	Diode short circuit (Requirement waiting the CP disconnected)	Fault--5#	EV-Charing Socket Fault
10	G	Blue+Red	2Hz flashing	PP line disconnection	Fault--6#	SPLIT PP wire, Please check the PP line
11	J	Red+Green+Blue	2Hz flashing	Electromagnetic Lock failed	Fault--7#	Electronic Lock Disabled
12	L	Blue	5Hz flashing	IC card failed	Fault--8#	RFID card is not valid
13	M	Red+Green	1Hz flashing	Circuit overload, DLB Mode activated	Fault--9#	Circuit overload, DLB Mode activated



## Naming Rule

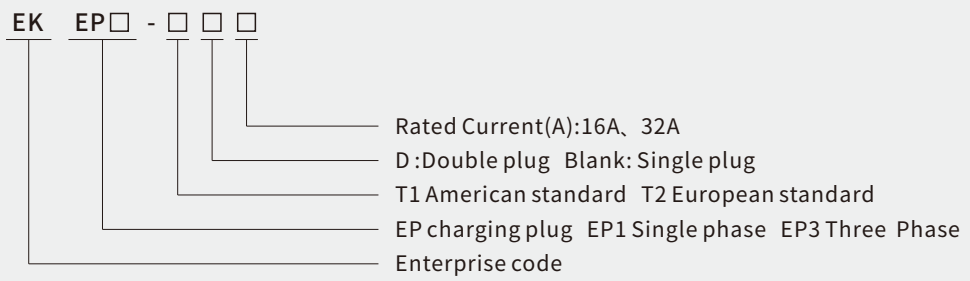

## Brief description

Human appearance design, beautiful and fashionable, in line with the modern aesthetics and ergonomic design concept, easy to use.  
The product conform to IEC62196-1, IEC62196-2 European standard and SAEJ1772-2010 American standard.  
Protection degree: IP54

## Product selection

Model	Specification	Cable
EKEP1-T2	Single phase : 16A	3*2.5mm <sup>2</sup> +0.5mm <sup>2</sup>
	Single phase : 32A	3*6mm <sup>2</sup> +0.5mm <sup>2</sup>
EKEP3-T2	Three phase : 16A	5*2.5mm <sup>2</sup> +0.5mm <sup>2</sup>
	Three phase : 32A	5*6mm <sup>2</sup> +0.5mm <sup>2</sup>

## Main parameter

### Electrical performance

Operation voltage	230V±10% 50Hz/400V±10%50Hz
Operation current	16A、32A
Continuously using time	Continuously working 24h
Conductive terminal temperature rise	≤50K
Insulation Resistance	≥500MΩ、DC500V
Withstand Voltage	2500V/min
Contact Resistance	≤0.3Ω

### Mechanical Features

Mechanical life	5,0000 times or more
Insertion / pulling force during connection	45N~80N
Withstanding impact	Tolerable to 2 ton car rolling or 1m height drop without damage

### Major material

Conductor material	Copper alloy + silver plating
Enclosure material	Thermoplastic flame retardant plastic, flame retardant grade UL94V-0

### Ambient condition

Ambient temperature	-40°C~+50°C
Humidity	<85%

## Product dimension

UNIT : MM

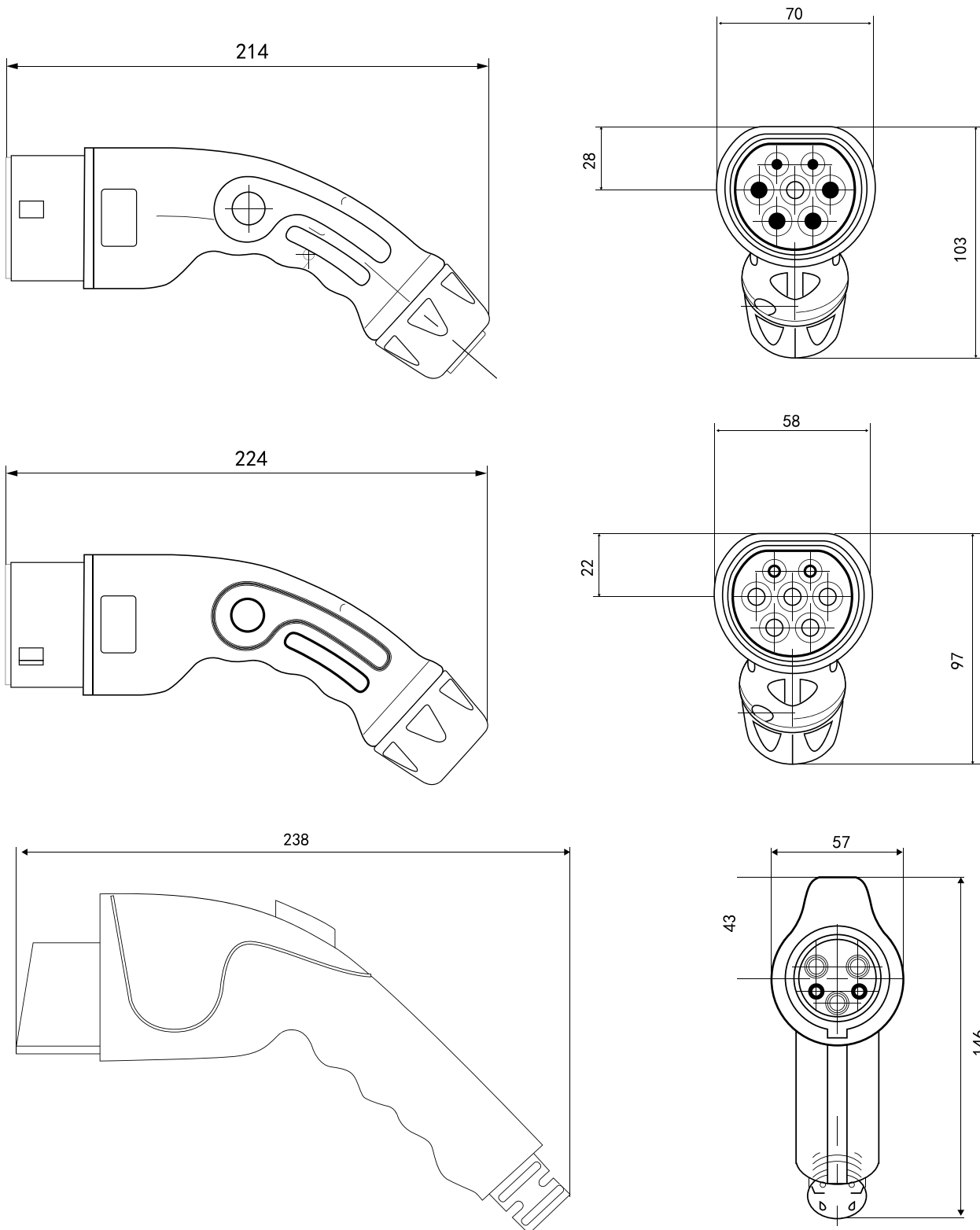



## Naming rules

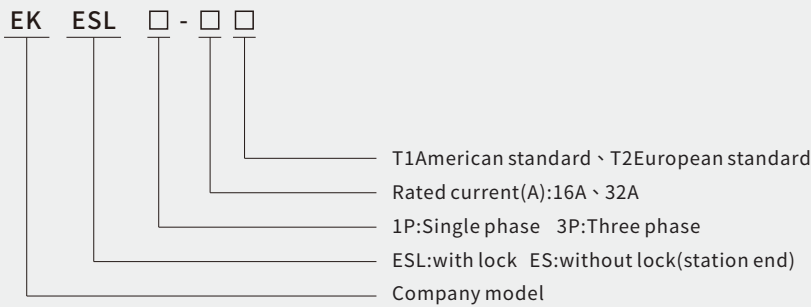

## Brief description

Human appearance design, beautiful and fashionable, in line with the modern aesthetics and ergonomic design concept, easy to use.

The product conform to IEC62196-2 SHEET2-11a standard.

Protection degree: IP54

Mainly used in the charging mode 3 of the IEC61851 standard

## Product selection

Model	Specification	Cable
EKES1-S-16-T2	Single phase : 16A/230V	3*2.5mm <sup>2</sup> +2*0.5mm <sup>2</sup>
EKES1-S-32-T2	Single phase : 32A/230V	3*6mm <sup>2</sup> +2*0.5mm <sup>2</sup>
EKES1-C-16-T2	Single phase : 16A/230V	3*2.5mm <sup>2</sup> +2*0.5mm <sup>2</sup>
EKES1-C-32-T2	Single phase : 32A/230V	3*6mm <sup>2</sup> +2*0.5mm <sup>2</sup>
EKES3-S-16-T2	Three phases : 16A/400V	5*2.5mm <sup>2</sup> +2*0.5mm <sup>2</sup>
EKES3-S-32-T2	Three phases : 32A/400V	5*6mm <sup>2</sup> +2*0.5mm <sup>2</sup>
EKES3-C-16-T2	Three phases : 16A/400V	5*2.5mm <sup>2</sup> +2*0.5mm <sup>2</sup>
EKES3-C-32-T2	Three phases : 32A/400V	5*6mm <sup>2</sup> +2*0.5mm <sup>2</sup>

## Main Parameter

### Electrical performance

Rated voltage	230V±10% 50Hz/400V±10% 50Hz
Rated current	16A, 32A
Usage time	Continuously working 24h
Conductive terminal temperature rise	≤50K
Insulation resistance	≥500MΩ, DC500V
Withstand voltage	2500V/min
Contact resistance	≤0.3Ω

### Mechanical performance

Mechanical life	5,000 times or more
Insertion / pulling force during connection	<100N(P), <75N(V)
Withstanding impact	Tolerable to 2 ton car rolling or 1m height drop without damage

### Major material

Conductor material	Copper alloy+ Ag plated
Enclosure material	Thermoplastic flame retardant material, flame retardant grade UL94V-0

### Ambient condition

Ambient temperature	-40°C-+50°C
Humidity	<85%

## Product dimension

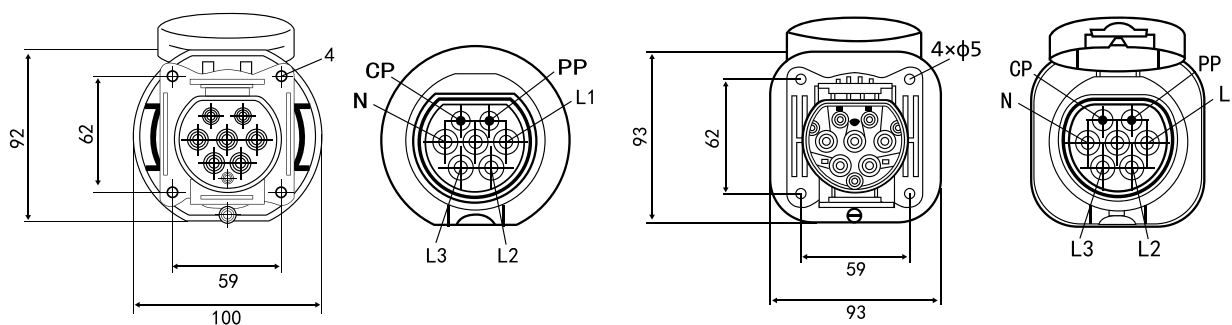

## Electromagnetic lock technical parameters

Working power supply	DC12V/500mA
Max. working current	≤500mA
No-load current	<50mA
Locking mechanism retention force	<80N
Locking mechanism breaking force	≥200N
Angle of rotation	≤90°
Response time	<50ms
Maximum power-on time	3.5s
Complete lock time	<300ms
Ambient humidity	-40°C-+80°C
Electrical life	≥3,0000 cycles
Insulation resistance	500MΩ
Power-on action time	0.2s<t<1.0s
Pulse duty factor	35%
Protection degree	IP55
Manual unlocking pull	≤5N
Manual unlock life	≥3,0000 cycles

## Function description

Red line(+12V)	Black line(0V)	Status	Feedback signal
+12V	0V	lock condition	Switch connected
0V	+12V	unlock condition	Switch disconnected

## Electrical wiring principle

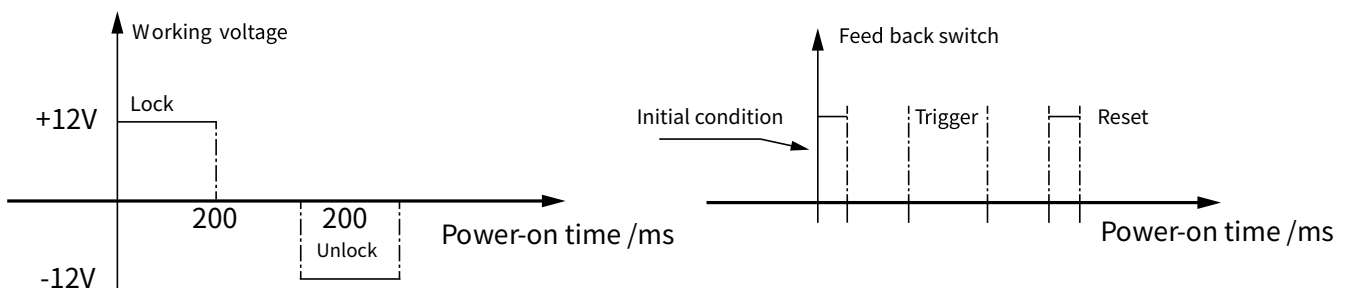
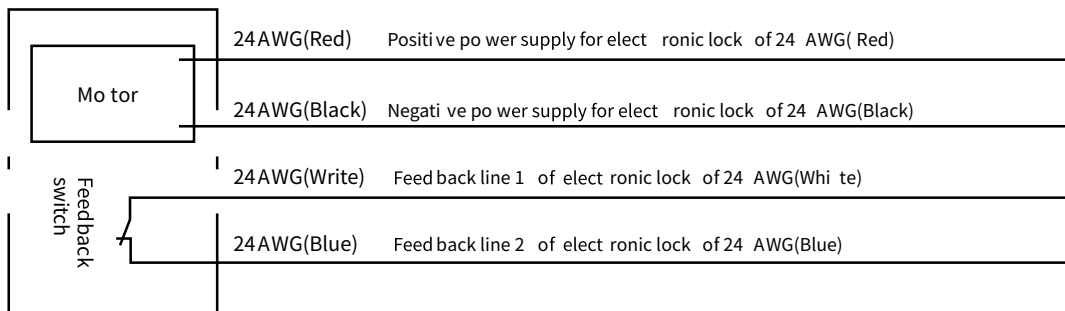





Appearance and installation dimension

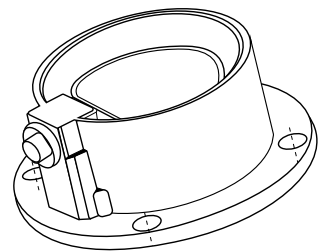
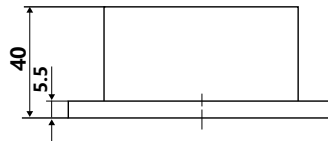
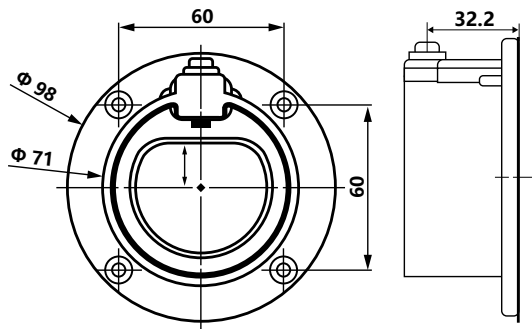

UNIT:MM

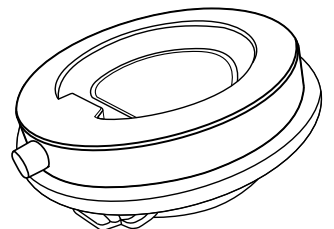
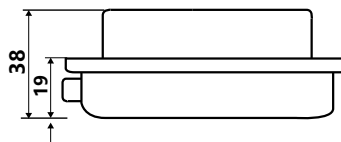
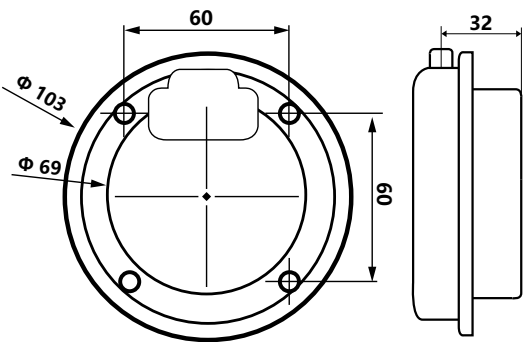

UNIT:MM



## Naming rules

EK EPC □ - □ □

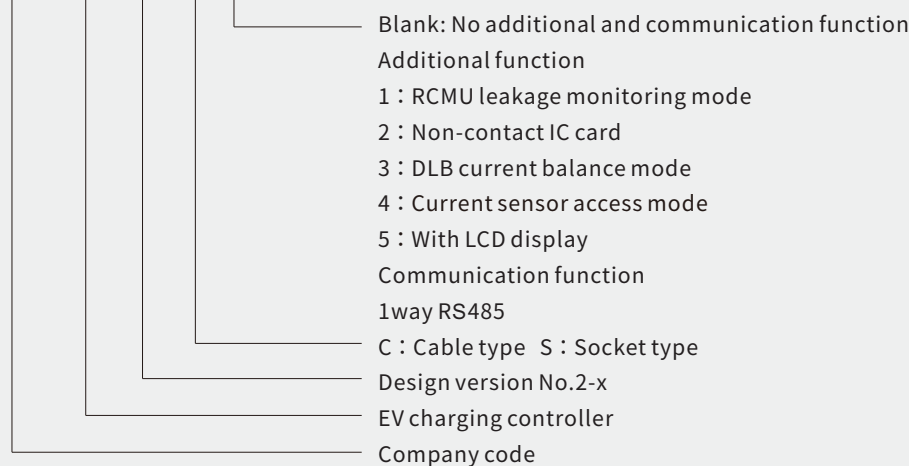

## Brief description

Control the communication of the electric vehicle AC charging process complies with IEC 61851 or SAEJ1772 standards. Conform to DIN EN60715 installation requirements.

The output of the relay is used to connect the AC contactor that switches on/off the load.

The operating status of the EV interface is indicated by three-color LED lights.

The controller additional functions include: non-contact IC card connection module, DC leakage detection module (RCMU), RS485 communication interface equipment, plug lock device, external emergency stop button, etc. These functions must be NOTED when ordering.

## Function specification

Technical date	Model specification	EKEPC2-C/S
Operating voltage		AC230V±10% 50Hz
Output the PWM signal		10A、16A、20A、25A、32A、63A
Output control AC contactor		Passive contacts
Additional connection function (optional)		1.RCMU leakage monitoring mode (0-20mA/0-200mA) 2.Non-contact IC Card 3.DLB current balance mode 4.Current sensor access mode (DC+12V Output 0-5V) 5.With LCD display
Communication function ( optional)		1 way RS485(Modebus-RTU)/RS232
Output auxiliary voltage		DC12V/100mA、DC5V/100mA
Ambient temperature		-40°C~+50°C
Humidity		≤85%
IP degree		IP22
Cooling method		Natural cooling
Installation method		DIN rail standard
Weight		40g
Overall dimension		

Maximum charging capacity indication 10A, 16A, 20A, 25A, 32A, Through the internal dial switch

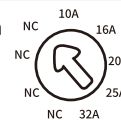

## Controller connection status

No.	State Code	LED Color	LED State	PE、CP、PP state	Controller state	Remark
0	K	Red	5Hz flashing	Power self detect failed	Fault--1#	Power self-check failed! Please turn the power back on!
1	A	Blue	1Hz flashing	CP disconnection	Ready	
2	I	Blue	2Hz flashing	Waiting for IC card	RFID Waiting	
3	B	Blue	Stabilization	CP connect to diode+2.7KΩ	Connected	
4	B	Blue	Stabilization	CP connect to diode+1.3KΩ	Connected	
5	C	Green	Green brightening	CP connect to diode+2.7KΩ parallelconnect1.3KΩ	Charging	
6	D	Red	Stabilization	CP connect to diode+2.7KΩparallelconnect1.3KΩ parallel connect 270R Or CP connect to diode+270R Or CP connect to diode+270R parallel connect 2.7KΩ Or CP connect to diode+270R parallel connect 1.3KΩ	Fault--2#	Need Ventilation!
7	F	Red	1Hz flashing	CP line short circuit with PE line	Fault--3#	CP- PE short circuit! Please check the CP line
8	H	Red	5 Hz flashing	RCMU occurs residual current or self detect failed	Fault--4#	RCMU leakage or self-inspection failure
9	E	Red	2Hz flashing	Diode short circuit (Requirement waiting the CP disconnected)	Fault--5#	EV-Charing Socket Fault
10	G	Blue+Red	2Hz flashing	PP line disconnection	Fault--6#	SPLIT PP wire, Please check the PP line
11	J	Red+Green+Blue	2Hz flashing	Electromagnetic Lock failed	Fault--7#	Electronic Lock Disabled
12	L	Blue	5Hz flashing	IC card failed	Fault--8#	RFID card is not valid
13	M	Red+Green	1Hz flashing	Circuit overload, DLB Mode activated	Fault--9#	Circuit overload, DLB Mode activated

## Controller charging procedure

After connected on the working voltage, the controller starts to initialize (self - detection procedure on the RCMU module) and conduct self - detection function (LED cycle flashing), waiting for the car to connect. The controller waits for the charging cable and the vehicle connection (status A), and the LED keeps flashing blue light, and this process requires about 6s waiting. If this controller connected the matched cable (status B), LED becomes stable blue light (and opens the electromagnetic lock switch).

After the charging plug linkage, and if the vehicle is in state C, the controller keeps the P1/P2 closed (charger connected), the LED becomes stable green, and the EV starts into charging mode. If the display status D( requires ventilation), because the controller does not have the heat dissipation function, the controller puts the P1/P2 on (charger off) simultaneously (close the electromagnetic lock switch), the head interlock fails and the controller turns off the charging program, the LED becomes stable red.

## Function application

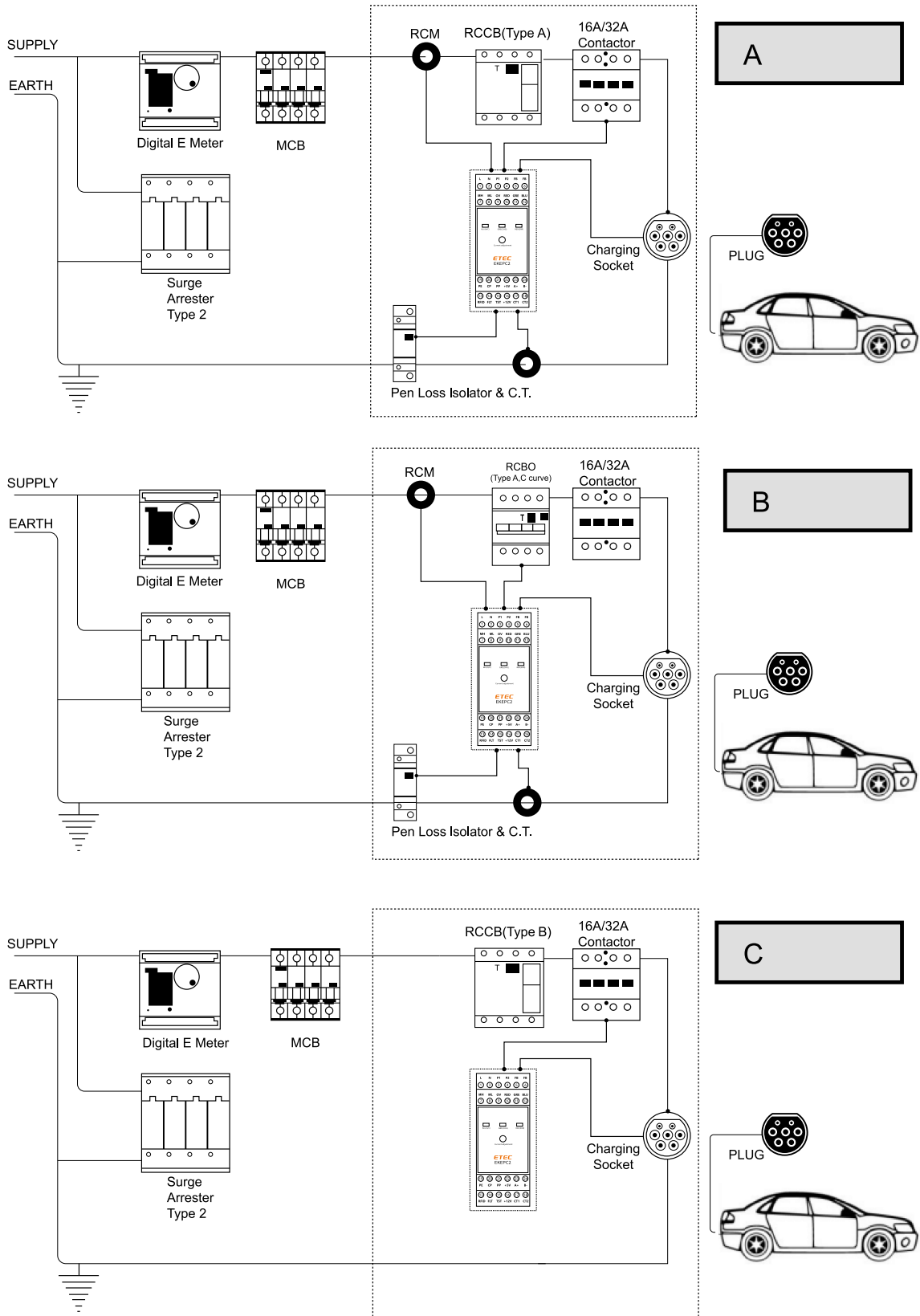

## Terminal description of the controller

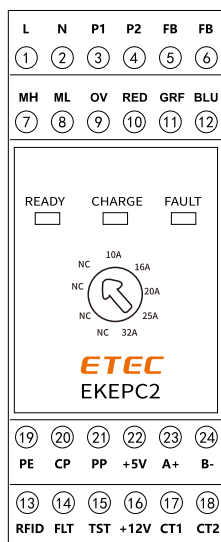

## Terminal function description

Serial number	Mark	function	Specification
1	L	Live line	Product working power supply:AC230V±10% 50Hz
2	N	Neutral line	
3	P1	Relay coil A1	AC contactor connected to the connection load of charging station
4	P2	Relay coil A2	
5	FB	Reflect signal of the electromagnetic lock	This is the feedback signal on the electromagnetic lock directly to the passive contact output terminal of the electromagnetic lock
6	FB		
7	LK+	Electromagnetic lock positive voltage	Provide positive and negative pulse voltage of electromagnetic lock, duty cycle of output pulse (1: 3) and total pulse output maximum driving capacity of 500ms
8	LK-	Electromagnetic lock negative voltage	
9	0V	Earth terminal	External indicator light, DC5V/10mA drive capability
10	RED	Red LED	
11	GRE	Blue LED	
12	BLU	Green LED	
13	IC	IC card - controlled input signal	The signal of external non-contact IC card reading module,input is TTL voltage signal,DC 3.3V/5V
14	FLT	RCMU fault signal(DC3.3V/5V), output terminal	When the controller detects this end signal, means this line occur fault (including≥DC6mA leakage signal), the controller will cut off the charging power, untill this fault signal is solved, the controller will automatic resumes the charging state.
15	TST	RCMU test signal(DC3.3V/5V), the input terminal	The controller outputs the test signal before each charging, using to check that the working of the RCMU whether normal
16	+12V	+12V Power Supply	DC+12V/100mA Power output
17	CT1	Current transformer	When the controller requires DLB function, it requires connect to current transformer signal, the signal is: AC0- 1.0V/0-50A.This function can dynamically balance the power load, adjust the output in time, control the charging current, and protect the safety of the power supply line.
18	CT2		
19	PE	Power supply	Earth terminal
20	CP	Connect to the vehicle CP	Communication connection with electric vehicle, output PWM wave
21	PP	Charging cable current identification	When this end is a socket type charging station, it identify the current specification of charging cable
22	+5V	+5V Power Supply	Supply DC 5V/100mA power output
23	A+	A +for RS485 Communications	It can communicate with RS485 equipment. The communication standard conforms to Modbus-RTU slave mode. Baud rate: 38400, N, 8, 1 address number default: 255(Broadcast address)See Table A for details
24	B-	B-for RS485 Communications	

## RS485 Communication description

Modbus-RTU model, Baud rate: 38400, fixed, address: 1-255 default: 255 (Broadcast address)

Register address number	Data description (power failure protection)	Read and write	Type of data	Defaults
100	Device address number	Read and write	16-bit integer	255
101	DLB maximum starting current	Read and write	16-bit integer	9000
102	DLB maximum current (100.00A)	Read and write	16-bit integer	10000
103	Reference current: DLB/current transformation ratio (100.00A)	Read and write	16-bit integer	10000
104	Reference current calibration value input	Read and write	16-bit integer	1270
105	Charging pile current transformation ratio 50-200A	Read and write	16-bit integer	
106	Charging pile current value correction 0-100.0A	Read and write	16-bit integer	
107	Charging pile voltage value correction 0-500.0V	Read and write	16-bit integer	
108	Charging pile power value correction 0-22000W	Read and write	16-bit integer	
109	Maximum output PWM duty cycle of charging pile	Read and write	16-bit integer	90%
110	RCMU function selection 0 disabled 1 enabled, other values are selected by DIP switch	Read and write	16-bit integer	3
111	RFID function selection 0 disabled 1 enabled, other values are selected by DIP switch	Read and write	16-bit integer	3
112	Lock function selection 0 disabled 1 enabled, other values are selected by DIP switch	Read and write	16-bit integer	3
113	Cable function version selection 0 disable 1 enable, other values are selected by DIP switch	Read and write	16-bit integer	3
114	DLB function selection 0 disable 1 enable, other values are selected by DIP switch	Read and write	16-bit integer	3
115	PID control parameter P of DLB	Read and write	16-bit integer	100
116	PID control parameters of DLB I	Read and write	16-bit integer	1
117	DLB PID control parameter D	Read and write	16-bit integer	100
118-119	Controller ID number up to 9 digits	Read and write	32-bit integer	
120-139	spare	Read and write		
140	Software version	Read only	16-bit integer	1002
141	Current working status: Corresponding status 0-13	Read only	16-bit integer	
142	PWM value of cable specification	Read only	16-bit integer	
143	RCMU status 00 Not selected 01 Normal operation 02 Self-check failed 03 There is leakage in the charging circuit	Read only	16-bit integer	
144	RFID status 00 not selected 01 IC card not operating 02 IC card closed 03 IC card open	Read only	16-bit integer	
145	Lock status 00 not selected 01 locked 02 unlocked 03 fault	Read only	16-bit integer	
146	The current current, the decimal place is determined by the value of the reference current	Read only	16-bit integer	
147	Current value of charging pile 0-200.0A	Read only	16-bit integer	
148	Current voltage value of charging pile 0-500.0V	Read only	16-bit integer	
149	Current power value of charging pile 0-22000W	Read only	16-bit integer	
150	Calibration value AD value of reference current	Read only	16-bit integer	
151	The PWM duty cycle corresponding to the current set by the rotary switch	Read only	16-bit integer	
152	Current output PWM duty cycle	Read only	16-bit integer	
153-160	spare	Read only	16-bit integer	

## Application circuit diagram

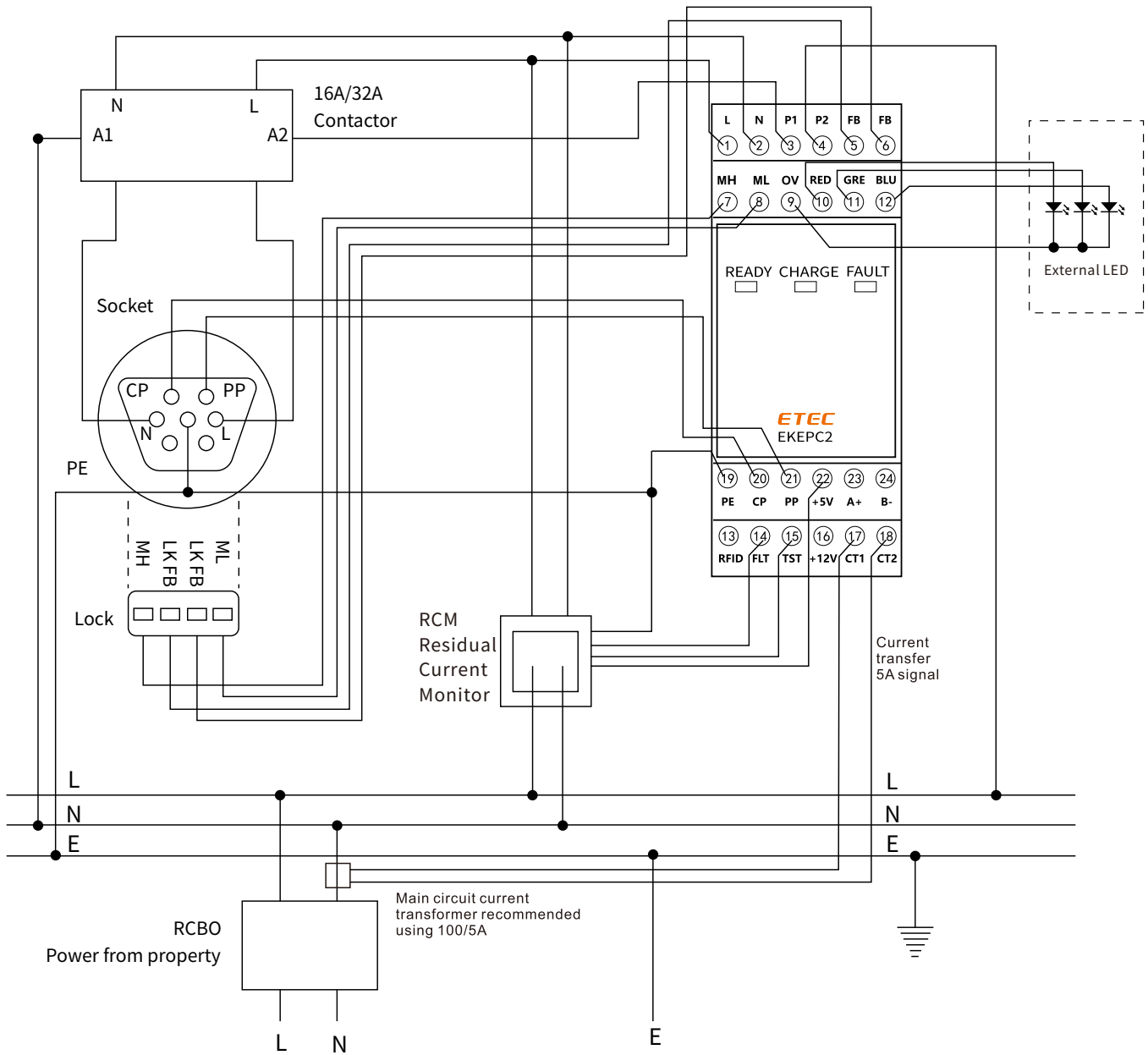

## Easy installation

1. Install the controller (a) vertically onto the horizontal DIN rail (b).
2. Rotate the controller down until the clip into the Din  
(Note: DIN rail accordance with German industrial standards)

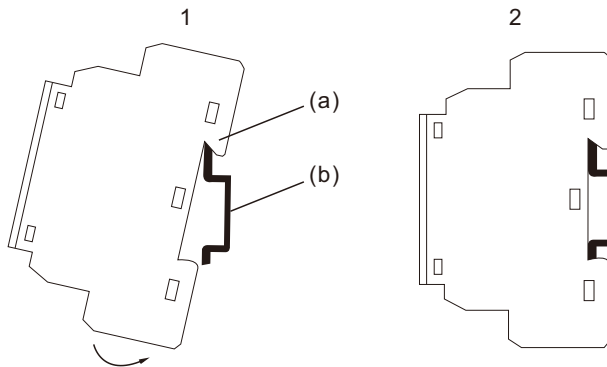

## Overall dimension(mm)

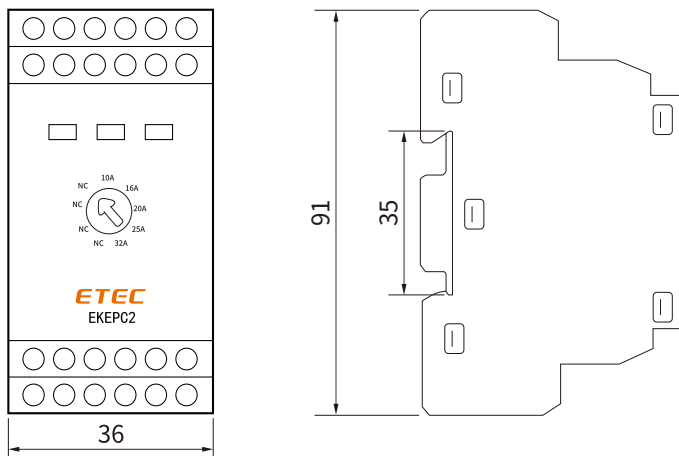



# EKL1-63B 10KA B Type RCCB

Residual Current Circuit Breaker

Standard IEC61008-1  
IEC62423



## Technical Data

### ◆ Electrical Features

Mode	Electromagnetic
Type(wave form of the earth leakage sensed)	B
Rated current In	25,40,63A
Poles	4P
Rated voltage Ue	4P 415V~
Insulation voltage Ui	500V
Rated frequency	50/60Hz
Rated residual operation current(IΔn)	30, 100, 300mA
Rated residual making and breaking capacity(IΔm)	500A(In≤40A), 10In(In>40A)
Short-circuit current Inc=IΔc	10,000A
SCPD fuse	10000
Break time under IΔn	≤0.1s
Rated impulse with stand voltage(1.5/50) Uimp	4000V
Dielectric test voltage at ind.Freq.for 1min	2.5kV
Electrical life	2,000 Cycles
Mechanical life	4,000 Cycles

### ◆ Installation

Contact position indicator	YES
Protection degree	IP20
Ambient temperature(with daily average ≤35°C)	-5°C~+40°C
Storage temperature	-25°C~+70°C
Terminal connection type	Cable/Pin-typebusbar/U-typebusbar
Terminal size top/bottom for cable	25mm <sup>2</sup> 18-3AWG
Terminal size top/bottom for busbar	25mm <sup>2</sup> 18-3AWG
Tightening torque	2.5Nm 22In-lbs
Mounting	On DIN rail EN60715(35mm) by means of fast clip device
Connection	Power supply in both directions

# EKL1-63B 10KA B Type RCCB



Residual Current Circuit Breaker

Standard IEC61008-1  
IEC62423

## Tripping Current Range

Type	Tripping current $I_{\Delta}/A$		
	$0.5I_{\Delta n} < I_{\Delta} < I_{\Delta n}$		
A	Lagging Angle	$I_{\Delta n} > 0.01A$	$I_{\Delta n} \leq 0.01A$
	0°	$0.35I_{\Delta n} \leq I_{\Delta} \leq 1.4I_{\Delta n}$	$0.35I_{\Delta n} \leq I_{\Delta} \leq 2I_{\Delta n}$
	90°	$0.25I_{\Delta n} \leq I_{\Delta} \leq 1.4I_{\Delta n}$	$0.25I_{\Delta n} \leq I_{\Delta} \leq 2I_{\Delta n}$
	135°	$0.11I_{\Delta n} \leq I_{\Delta} \leq 1.4I_{\Delta n}$	$0.11I_{\Delta n} \leq I_{\Delta} \leq 2I_{\Delta n}$

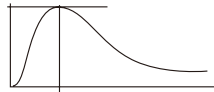
Detectable waveform	Pulsating direct current sensitive	Surge current proof
<p>B class</p> <p>Tripping is ensured for sinusoidal AC residual currents pulsed DC residual currents, alternating residual sinusoidal currents up to 1000Hz, pulsating direct residual currents and for smooth direct residual currents, whether applied suddenly or increasing slowly.</p>	 <p>They react to AC and pulsating DC fault current which reach 0 or almost 0 within one time period of the mains frequency.</p>	 <p>RCCB's surge capacity. Not tripping at standardized 8/20 <math>\mu s</math> surge-current waves acc.to VDE 0432 Part2 with surge current values of up to 250A.</p>

## Circuit Diagram

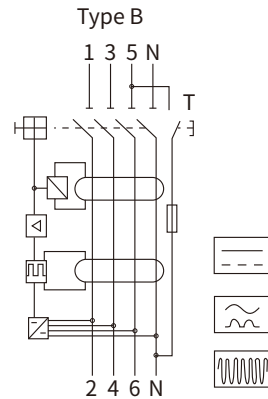

## Overall and Installation Dimension(mm)

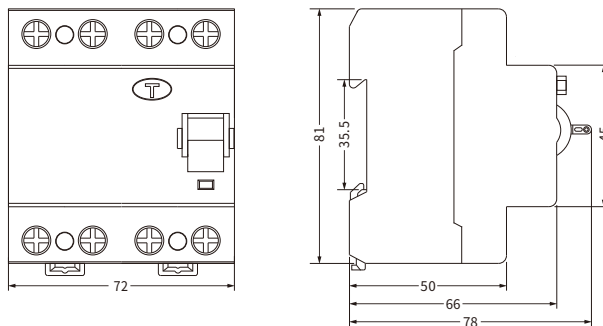

# EKL6-100B 10KA B Type RCCB

Residual Current Circuit Breaker

Standard IEC61008-1  
IEC62423



## Technical Data

### ◆ Electrical Features

Mode	Electromagnetic
Type(wave form of the earth leakage sensed)	B
Rated current $I_n$	25,40,63,80,100A
Poles	
Rated voltage $U_e$	
Insulation voltage $U_i$	500V
Rated frequency	50/60Hz
Rated residual operation current ( $I_{\Delta n}$ )	30mA
Rated residual making and breaking capacity( $I_{\Delta m}$ )	500A( $I_n \leq 40A$ ), 10In( $I_n > 40A$ )
Short-circuit current $I_{nc} = I_{\Delta c}$	10,000A
SCPD fuse	10000
Break time under $I_{\Delta n}$	$\leq 0.1s$
Rated impulse with stand voltage(1.5/50)U <sub>imp</sub>	4000V
Dielectric test voltage at ind.Freq. for 1min	2.5kV
Electrical life	2,000 Cycles
Mechanical life	4,000 Cycles

### ◆ Installation

Contact position indicator	YES
Protection degree	IP20
Ambient temperature(withdailyaverage $\leq 35^\circ C$ )	$-5^\circ C \sim +40^\circ C$
Storage temperature	$-25^\circ C \sim +70^\circ C$
Terminal connection type	Cable/Pin-typebusbar/U-typebusbar
Terminal size top/bottom for cable	35mm <sup>2</sup> 18-3AWG
Terminal size top/bottom for busbar	35mm <sup>2</sup> 18-3AWG
Tightening torque	2.5Nm 22In-lbs
Mounting	On DINrail EN60715(35mm)by means of fast clip device
Connection	Power supply in both directions

# EKL6-100B 10KA B Type RCCB



Residual Current Circuit Breaker ..... **Standard** IEC61008-1 IEC62423

## Tripping Current Range

Type	Tripping current $I_{\Delta}/A$		
	$0.5I_{\Delta n} < I_{\Delta} < I_{\Delta n}$		
A	Lagging Angle	$I_{\Delta n} > 0.01A$	$I_{\Delta n} \leq 0.01A$
	0°	$0.35I_{\Delta n} \leq I_{\Delta} \leq 1.4I_{\Delta n}$	$0.35I_{\Delta n} \leq I_{\Delta} \leq 2I_{\Delta n}$
	90°	$0.25I_{\Delta n} \leq I_{\Delta} \leq 1.4I_{\Delta n}$	$0.25I_{\Delta n} \leq I_{\Delta} \leq 2I_{\Delta n}$
	135°	$0.11I_{\Delta n} \leq I_{\Delta} \leq 1.4I_{\Delta n}$	$0.11I_{\Delta n} \leq I_{\Delta} \leq 2I_{\Delta n}$

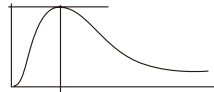
Detectable waveform	Pulsating direct current sensitive	Surge current proof
<p>B class</p> <p>Tripping is ensured for sinusoidal AC residual currents pulsed DC residual currents, alternating residual sinusoidal currents up to 1000Hz, pulsating direct residual currents and for smooth direct residual currents, whether applied suddenly or increasing slowly.</p>	 <p>They react to AC and pulsating DC fault current which reach 0 or almost 0 within one time period of the mains frequency.</p>	 <p>RCCB's surge capacity. Not tripping at standardized 8/20 μs surge-current waves acc.to VDE 0432 Part2 with surge current values of up to 250A.</p>

## Circuit Diagram

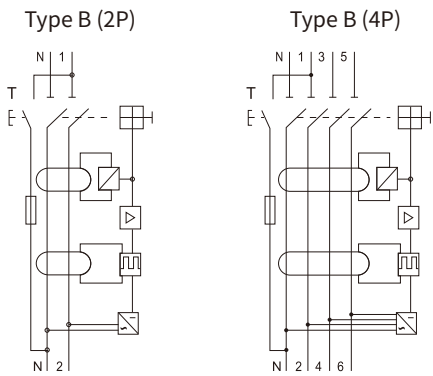

## Overall and Installation Dimension(mm)

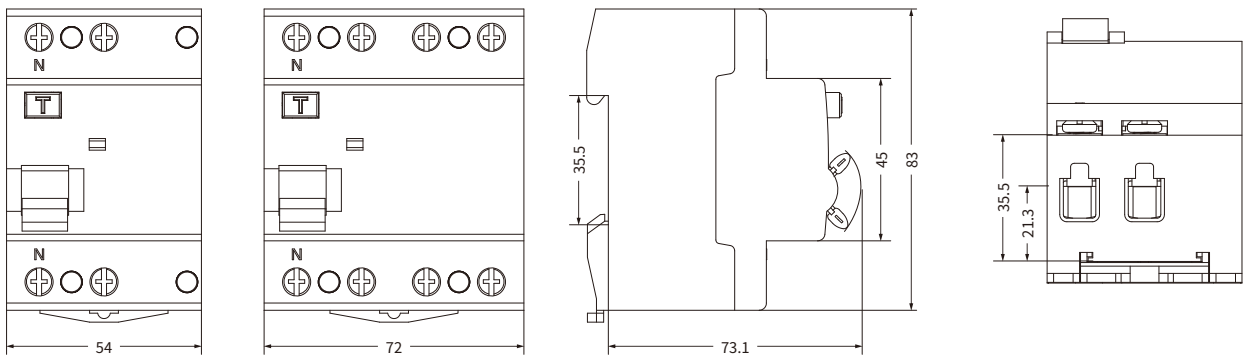

### Automatic Type



2P/25A



4P/25A



2P/40, 63A



4P/40, 63A



Aux.

### Manual Type



2P/25A



4P/25A



2P/40, 63A



4P/40, 63A

## Technical Data

### ◆ Electrical Features

Voltage rating (Ue)	1P, 2P	
	3P, 4P	
Frequency		50/60Hz
Endurance (O-C)		1,000,000
Electrical life		100,000
Maximum number of switching operation a day		100
Additional characteristics		
Insulation voltage (Ui)		
Pollution degree		2
Rated impulse with stand voltage (Uimp)		
Degree of protection (IEC 60529)		IP20
		IP40
Operating temperature		-5°C ~ +60°C <sup>(1)</sup>
Storage temperature		-40°C ~ +70°C
Tropicalization (IEC 60068-1)		Treatment 2 (relative humidity 95% at 55°C)

ELSV compliance (Extra Low Safety Voltage) for 12/24/48VAC versions

The product control conforms to the SELV (safety extra low voltage) requirements

(1) In the case of contactor mounting in an enclosure for which the interior temperature is in range between 50°C and 60°C, it is necessary to use a spacer, between each contactor.

Connection

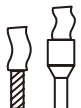
Type	Rating(In)	Lenght tripping	Circuit	Tightening torque	Copper cables	
					Rigid	Flexible or ferrule
EKMF	PZ1:4MM	16-100A	Control	0.8N.m		
		16~25A			1.5~2.5mm <sup>2</sup> 2×1.5mm <sup>2</sup>	1.5~2.5mm <sup>2</sup> 2×2.5mm <sup>2</sup>
	PZ2:6MM	40A-63A	Power	3.5N.m	1.5~6mm <sup>2</sup>	1~4mm <sup>2</sup>
		100A			6~25mm <sup>2</sup> 6×3.5mm <sup>2</sup>	6~16mm <sup>2</sup> 6~35mm <sup>2</sup>

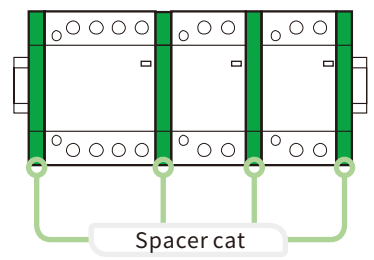
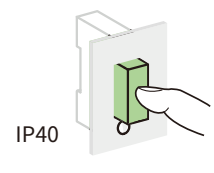
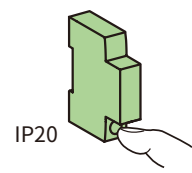
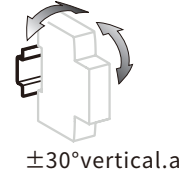
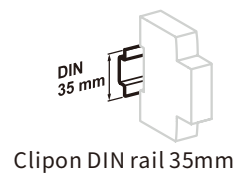
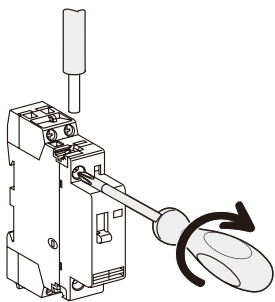

EKMF Contactors-50Hz

	Rating(In)		Control voltage (VAC)(50/60Hz)	Consumption		Max.power
				Holding	Inrush	
2P	16A	6A	220...240			1.2W
	20A	7A	220...240			1.2W
	25A	9A	220...240			1.2W
	40A	18A	220...240			1.6W
	63A	25A	220...240			1.6W
	100A	-	220...240			2.1W
4P	16A	6A	220...240			1.6W
	25A	9A	220...240			1.6W
	32A	12A	220...240			2.1W
	40A	18A	220...240			2.1W
	63A	25A	220...240			2.1W
	100A	-	220...240			4.2W

EKMF Manual Control Contactor-50Hz

	Rating(In)		Control voltage (VAC)(50/60Hz)	Consumption		Max.power
				Holding	Inrush	
2P	25A	9A	220...240			1.2W
	40A	18A	220...240			1.6W
	63A	25A	220...240			1.6W
4P	25A	9A	220...240			1.6W
	40A	18A	220...240			2.1W
	63A	25A	220...240			2.1W

Circuit Diagram

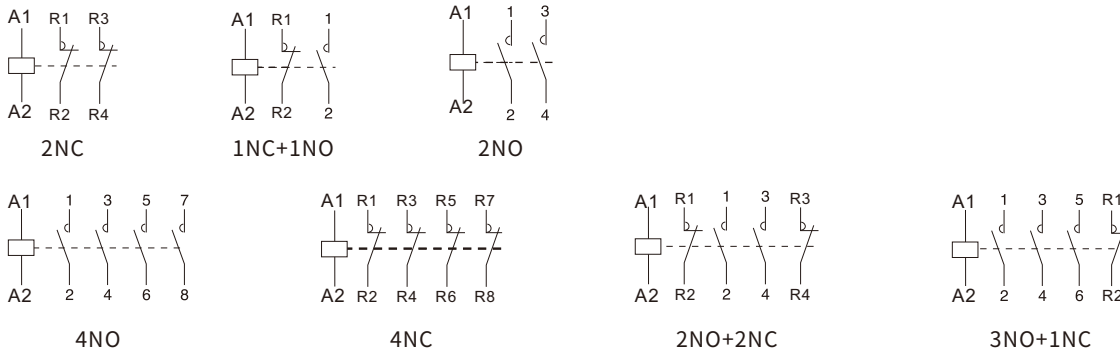

Overall and Installation Dimension (mm)

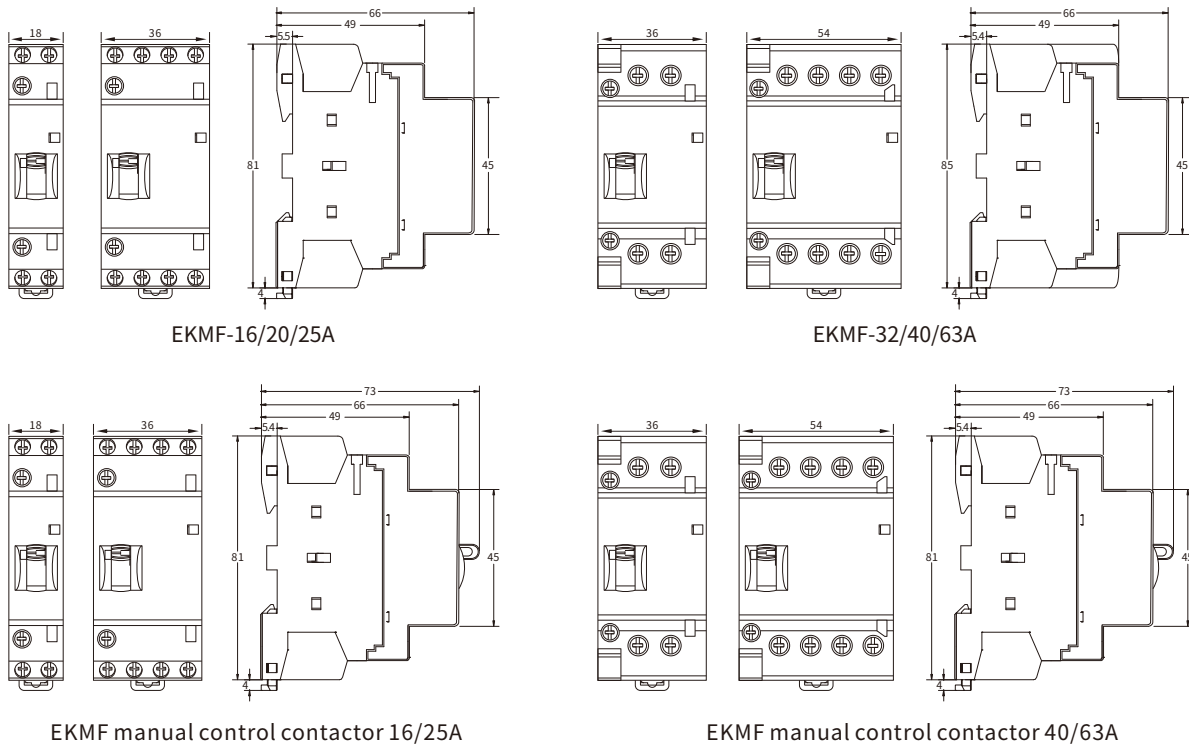

EKMF manual control contactor 16/25A

EKMF manual control contactor 40/63A

 The information in this manual is printed by Yiteng electric. The pictures in the manual are only used to explain the relevant information of this series of products for reference. Yiteng electric may at any time improve the relevant contents of this manual due to technical upgrading or the adoption of updated production process, or make necessary improvements and changes to the printing errors and inaccurate information of this manual without prior notice.

## ZHEJIANG ETEK ELECTRICAL TECHNOLOGY CO.,LTD.

 [Http://www.etek-electric.com](http://www.etek-electric.com)

 Head office: 0086-577-62718777  
Sales office: 0086-571-87837035

 Head office: sales@etek-china.com  
Sales office: sales@etek-electric.com

 Wenzhou ETEK (Head office):  
No.288 Wei 17th Road,Economic Development Zone,Yueqing City,Zhejiang China.  
Hangzhou ETEK (Sales office):  
No.411-412,Building 16,Singapore-Hangzhou Science&Technology Park,Baiyang Street,  
Qiantang New Zone,Hangzhou City Zhejiang China.

