

# DIN-RAIL/MODULAR TYPE DISTRIBUTION ELECTRIC





# MAIN PRODUCTS



ZHEJIANG ETEK  
ELECTRICAL TECHNOLOGY CO.,LTD.

## S1(Series No.1)

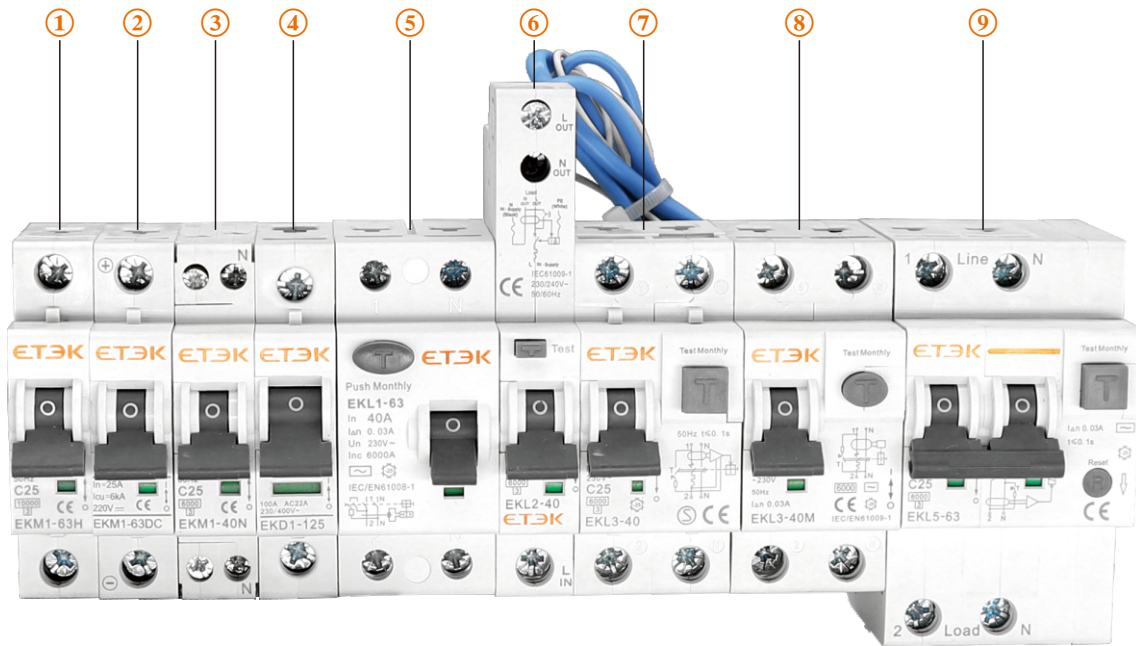

- |  |   |
|--|---|
| 1) MCB, Breaking Capacity 6/10KA, In:1-63A (Page 03-06)                        | 6) RCBO W=18MM Electronic type, Breaking Capacity 6KA, In:6-40A (Page 17-18)      |
| 2) DC MCB, Breaking Capacity 6/10KA, In:1-63A (Page 07-08)                     | 7) RCBO W=36MM Electronic type, Breaking Capacity 6KA, In:6-40A (Page 19-20)      |
| 3) MCB 1P+N W=18MM, Breaking Capacity 6KA, In:1-40A (Page 09-10)               | 8) RCBO W=36MM Electromagnetic type, Breaking Capacity 6KA, In:6-40A (Page 21-22) |
| 4) Isolation Switch, In: 32-125A (Page 25)                                     | 9) RCBO Electronic type, Breaking Capacity 6/10KA, In:6-63A (Page 23-24)          |
| 5) RCCB Electromagnetic type, Breaking Capacity 6/10KA, In:25-63A (Page 13-14) |   |

## S2(Series No.2)

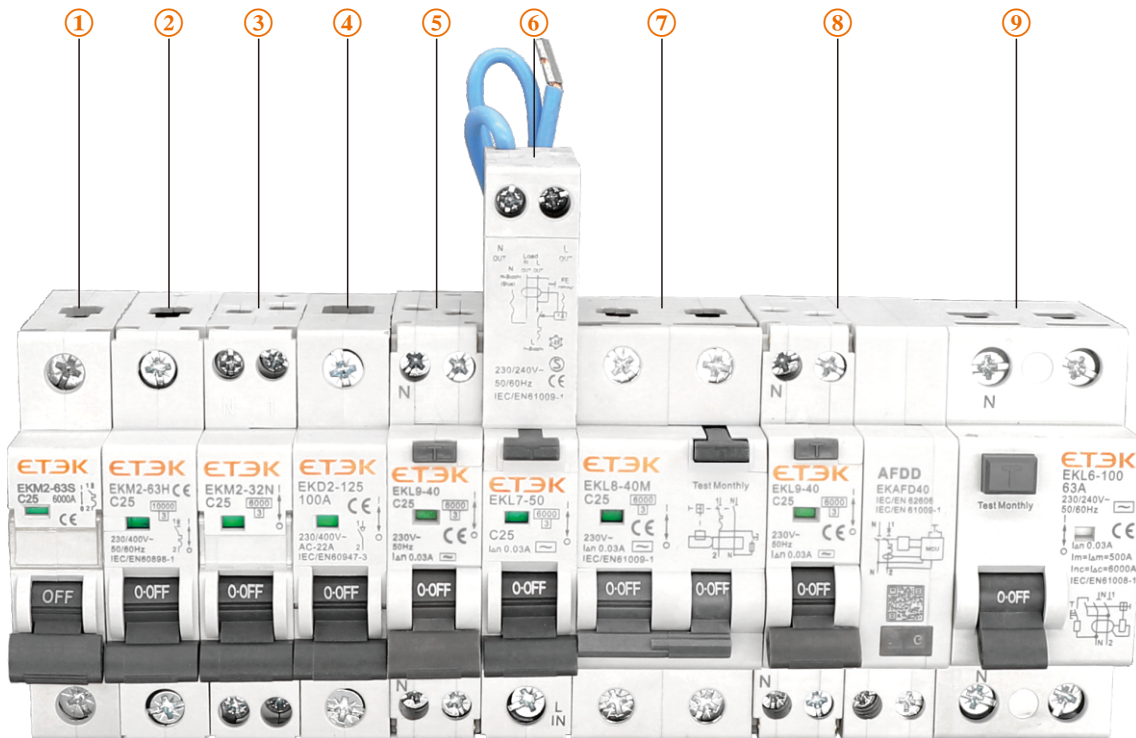

- |  |   |
|--|---|
| 1) MCB, Breaking Capacity 4.5KA, In:1-63A (Page 29-30)                       | 6) RCBO W=18MM Electronic type, Breaking Capacity 6/10KA, In:6-50A (Page 43-44)   |
| 2) MCB, Breaking Capacity 6/10KA, In:1-63A (Page 31-34)                      | 7) RCBO W=36MM Electromagnetic type, Breaking Capacity 6KA, In:6-40A (Page 45-46) |
| 3) MCB 1P+N W=18MM, Breaking Capacity 6KA, In:1-32A (Page 35-36)             | 8) AFDD + RCBO, Electronic type, Breaking Capacity 6KA, In:6-40A (Page 47-49)     |
| 4) Isolation Switch, In: 32-125A (Page 50)                                   | 9) RCCB Electromagnetic type, Breaking Capacity 6/10KA, In:25-100A (Page 39-40)   |
| 5) RCBO W=18MM Electronic type, Breaking Capacity 6KA, In:6-40A (Page 47-48) |   |



# COMPANY

## >>> INTRODUCTION



Zhejiang ETEK Electrical Technology Co.,Ltd. was founded on January of 2011, which has more than 200 employees now. It is a professional manufacturing company engaging in R & D, production and sale of high and low voltage electrical products, such as Terminal distribution electrical appliances, Industrial distribution electrical appliances, Industrial control electrical appliances, DC systems distribution appliances, etc. It possesses three major manufacturing departments and one import & export trading company. The three manufacturing departments are Terminal distribution electrical appliances manufacturing department, Industrial distribution electrical appliances manufacturing department and Industrial control electrical appliances manufacturing department.

The series of products manufactured by the company are mainly sold to international market. All the products produced are in strictly accordance with international IEC/EN standards and China's GB standards. Most of these product have gained TUV and Intertek issued CCC,CE,TUV,SEMKO,EAC,SAA,INMETRO,ISO9001-2008 certificates and CB test reports. The products are sold to more than 50 countries and regions throughout the world, such as UK, France, Australia, Russia, Ukraine, Turkey, Brazil and so on. The quality of the products has been widely praised by the majority of users.

Wenzhou Wangke Trading Co.,Ltd. was founded on May of 2014,which is mainly responsible for the import & export business of Zhejiang ETEK Electrical Technology Co.,Ltd. and other holding companies.it has 25 employees and have been equipped with 5 main departments, which includes purchase department, sales department, quality inspection department, transportation department and financial department. Wangke Trading Co.,Ltd. focuses on ETEK product marketing development, global sales network construction, ETEK brand building and after-sales service. The team of Wangke is constantly learning to improve and is committed to building China's first class electrical products sales company.

**RoHS**

**EAC**



**CB**



**CE**

## WORKSHOPS



## MAIN PRODUCTS CLASSIFICATION CHART

Manufacturing department of ETEK Electric	Terminal Power Distribution	MCB	
		RCCB & RCBO	
		Isolation Switch	
		Accessories of Breakers	
		Modular Contactor	
		Modular Indicator & Socket	
		Other Modular Products	
	Industrial Power Distribution	MCCB	
		ACB	
		MPCB	
		ATS	
		Isolator	
	Industrial Control	Contactor	
		Thermal Relay	
		Electromagnetic Starter	
		Push Button Switch	
		LED Indicator & Voltage Meter	

# LOW-VOLTAGE ELECTRICAL TESTING CENTER

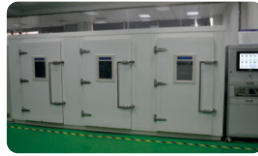
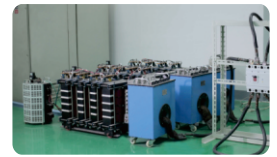
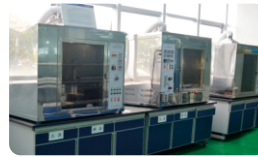

## Test Capabilities List

### I. Electromagnetic compatibility laboratory

- 1.Lightning surge immunity test
- 2.Pulse immunity test of electric fast transient group
- 3.Electrostatic Discharge immunity test
- 4.Power frequency magnetic field resistance test
- 5.Verify the performance
- 6.Residual current tripping test
- 7.2-stage power frequency withstand voltage test
- 8.Impulse withstand voltage test, leakage current test of RCBO under the condition of surge current generated by impulse voltage

### II. Mechanical life laboratory

- 1.Mechanical life test of Mini Circuit Breaker
- 2.Mechanical life test of Moulded Case Circuit Breaker
- 3.Mechanical life test of AC Contactor
- 4.Small reclosing electrical life test of Electrical Meter External Circuit Breaker

### III. High current characteristic laboratory

- 1.Temperature rise test of Circuit Breaker
- 2.Characteristics test of Circuit Breaker
- 3.Reliability test of Intelligent Circuit Breaker Test of Circuit Breaker
- 4.Product packaging simulation transport vibration

### IV. Material property laboratory

- 1.Thermal bimetallic deflection measurement test
- 2Automatic High Voltage continuous film test of enamelled Wire
- 3.Thermal softening breakdown test of enamelled wire
- 4.Enamelled wire stripping test
- 5.Simply supported beam impact test
- 6.Loop resistance test
- 7.Intelligent low resistance test

### V. Insulating material laboratory

- 1.Thermal and Ignition Resistance test of Insulation Materials
- 2.Horizontal vertical combustion
- 3.Insulating materials-determination of the relative leakage mark index
- 4.Salt spray corrosion resistance test
- 5.5-stage power frequency voltage resistance test

### VI. Environmental test chamber

- 1.High and low temperature hygrothermal test
- 2.Circuit board aging test
- 3.Constant temperature test
- 4.Action characteristics test of AC Contacto
- 5.Measuring instruments

### VII. Comprehensive characteristic laboratory

- 1.Temperature rise, reliability test of circuit breaker
- 2.Small reclosing characteristic test
- 3.Js7 delay characteristics testing
- 4.Overloading characteristics test of circuit breaker
- 5.Temperature rise test of CAC Contactor

## International Team



## Main Exhibition

HANNOVER MESSE	Hannover
MEE	Dubai
FIEE	Sao Paulo
CANTON FAIR	Guangzhou



# EKM1-63S 4.5KA/6KA MCB

Mini Circuit Breaker

**ETEK**<sup>®</sup>

Standard\_ IEC60898-1



## Technical Data

<b>Electrical Features</b>	Rated current $I_n$	1,2,3,4,5,6,8,10,13,16,20,25,32,40,50,63A
	Poles	1P, 1P+N, 2P, 3P, 3P+N, 4P
	Rated voltage $U_e$	240/415V~
	Insulation voltage $U_i$	500V
	Rated frequency	50/60Hz
	Rated breaking capacity	1-40A 6,000A / 50-63A 4,500A
	Energy limiting class	3
	Rated impulse withstand voltage(1.5/50) $U_{imp}$	4,000V
	Dielectric test voltage at ind. Freq. for 1 min	2kV
	Pollution degree	2
Thermo-magnetic release characteristic	B,C,D	
<b>Mechanical Features</b>	Electrical life	4,000 Cycles
	Mechanical life	10,000 Cycles
	Contact position indicator	Yes
	Protection degree	IP20
	Reference temperature for setting of thermal element	30°C
	Ambient temperature (with daily average $\leq 35^\circ\text{C}$ )	-5°C~+40°C
Storage temperature	-25°C~+70°C	
<b>Installation</b>	Terminal connection type	Cable/Pin-type busbar
	Terminal size top/bottom for cable	25mm <sup>2</sup> 18-3AWG
	Terminal size top/bottom for busbar	25mm <sup>2</sup> 18-3AWG
	Tightening torque	2.5Nm 22In-lbs
	Mounting	On DIN rail EN60715(35mm) by means of fast clip device
	Connection	From top and bottom
<b>Combination with accessories</b>	Auxiliary contact	EKM1S-OF
	Alarm contact	EKM1S-FB
	Shunt release	EKM1S-MX
	Over/Under voltage release	EKM1S-MV+MN



# EKM1-63S 4.5KA/6KA MCB

Mini Circuit Breaker



Standard\_ IEC60898-1

## MCB Characteristics

### Characteristics Curves

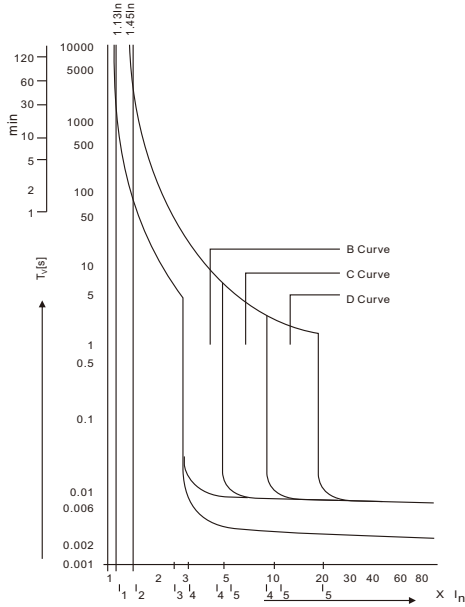

As per IEC60898	Thermal Tripping		Magnetic Tripping			
	No tripping current	Tripping current $I_2$	Time Limits t	Hold current $I_4$	Trip current $I_5$	Time Limits t
B Curve	$1.13 \times I_N$		$\geq 1h$ $< 1h$	$3 \times I_N$		$\geq 0.1s$ $< 0.1s$
C Curve	$1.13 \times I_N$		$\geq 1h$ $< 1h$	$5 \times I_N$		$\geq 0.1s$ $< 0.1s$
D Curve	$1.13 \times I_N$		$\geq 1h$ $< 1h$	$10 \times I_N$		$\geq 0.1s$ $< 0.1s$

### Tripping characteristics

Based on the Tripping Characteristics, MCB are available in “B”, “C” and “D” curve to suit different types of applications.

“B” Curve for protection of electrical circuits with equipment that does not cause surge current (lighting and distribution circuits) Short circuit release is set to (3-5)In.

“C” Curve for protection of electrical circuits with equipment that cause surge current (inductive loads and motor circuits) Short circuit release is set to (5-10)In.

“D” Curve for protection of electrical circuits with cause high inrush current, typically 12-15 times the thermal rated current (transformes, x-ray machines etc,) Short circuit release is set to (10-20)In.

### Circuit Diagram

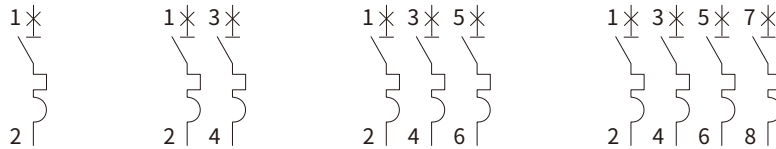

## Overall and Installation Dimension(mm)

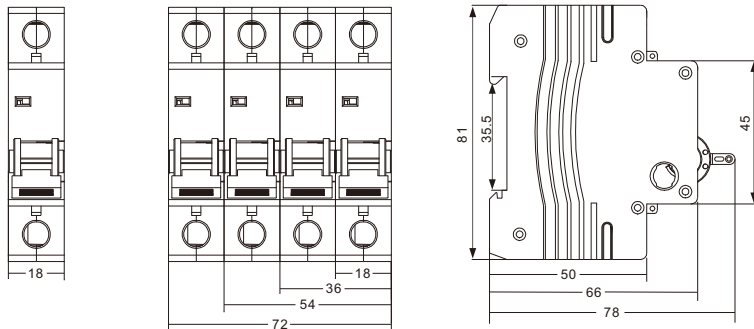

# EKM1-63 6KA MCB

Mini Circuit Breaker

**ETEK**<sup>®</sup>

Standard\_ IEC60898-1



## Technical Data

<b>Electrical Features</b>	Rated current $I_n$	1,2,3,4,5,6,8,10,13,16,20,25,32,40,50,63A
	Poles	1P, 1P+N, 2P, 3P, 3P+N,4P
	Rated voltage $U_e$	240/415V~
	Insulation voltage $U_i$	500V
	Rated frequency	50/60Hz
	Rated breaking capacity	6,000A
	Energy limiting class	3
	Rated impulse withstand voltage(1.5/50) $U_{imp}$	4,000V
	Dielectric test voltage at ind. Freq. for 1 min	2kV
	Pollution degree	2
Thermo-magnetic release characteristic	B,C,D	

<b>Mechanical Features</b>	Electrical life	8,000 Cycles
	Mechanical life	20,000 Cycles
	Contact position indicator	Yes
	Protection degree	IP20
	Reference temperature for setting of thermal element	30°C
	Ambient temperature (with daily average $\leq 35^\circ\text{C}$ )	-5°C~+40°C
	Storage temperature	-25°C~+70°C

<b>Installation</b>	Terminal connection type	Cable/Pin-type busbar/U-type busbar
	Terminal size top/bottom for cable	25mm <sup>2</sup> 18-3AWG
	Terminal size top/bottom for busbar	25mm <sup>2</sup> 18-3AWG
	Tightening torque	2.5Nm 22In-lbs
	Mounting	On DIN rail EN60715(35mm) by means of fast clip device
	Connection	From top and bottom

<b>Combination with accessories</b>	Auxiliary contact	EKM1-OF
	Alarm contact	EKM1-FB
	Shunt release	EKM1-MX
	Over/Under voltage release	EKM1-MV+MN

### MCB Characteristics

#### Characteristics Curves

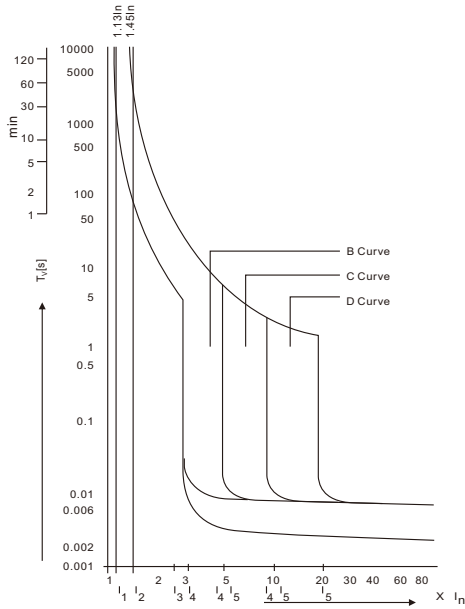

As per IEC60898	Thermal Tripping		Magnetic Tripping			
	No tripping current	Tripping current $I_2$	Time Limits t	Hold current $I_4$	Trip current $I_5$	Time Limits t
B Curve	$1.13 \times I_N$	$1.45 \times I_N$	$\geq 1h$ $< 1h$	$3 \times I_N$	$5 \times I_N$	$\geq 0.1s$ $< 0.1s$
C Curve	$1.13 \times I_N$	$1.45 \times I_N$	$\geq 1h$ $< 1h$	$5 \times I_N$	$10 \times I_N$	$\geq 0.1s$ $< 0.1s$
D Curve	$1.13 \times I_N$	$1.45 \times I_N$	$\geq 1h$ $< 1h$	$10 \times I_N$	$20 \times I_N$	$\geq 0.1s$ $< 0.1s$

#### Tripping characteristics

Based on the Tripping Characteristics, MCB are available in “B”, “C” and “D” curve to suit different types of applications.

“B” Curve for protection of electrical circuits with equipment that does not cause surge current (lighting and distribution circuits) Short circuit release is set to (3-5)  $I_N$ .

“C” Curve for protection of electrical circuits with equipment that cause surge current (inductive loads and motor circuits) Short circuit release is set to (5-10)  $I_N$ .

“D” Curve for protection of electrical circuits with cause high inrush current, typically 12-15 times the thermal rated current (transformes, x-ray machines etc,) Short circuit release is set to (10-20)  $I_N$ .

#### Circuit Diagram

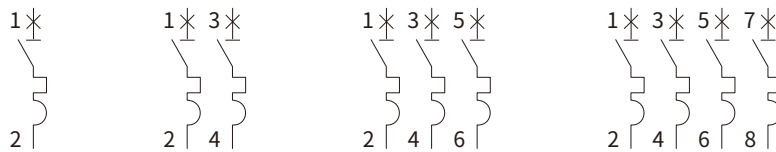

### Overall and Installation Dimension(mm)

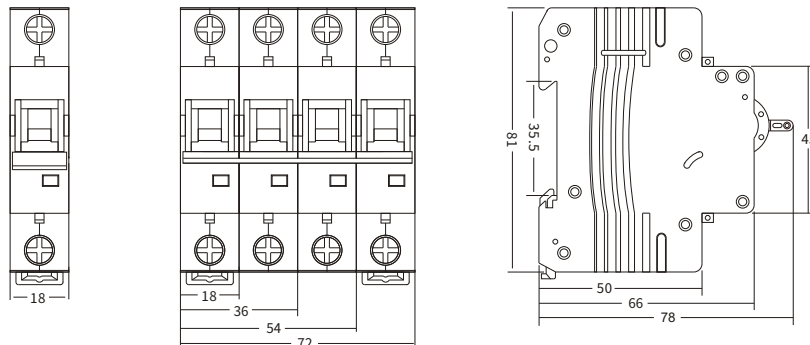

# EKM1-63H 10KA MCB

Mini Circuit Breaker

**ETEK**<sup>®</sup>

Standard\_ IEC60898-1



## Technical Data

<b>Electrical Features</b>	Rated current $I_n$	1,2,3,4,5,6,8,10,13,16,20,25,32,40,50,63A
	Poles	1P, 1P+N, 2P, 3P, 3P+N,4P
	Rated voltage $U_e$	230/400V~
	Insulation voltage $U_i$	500V
	Rated frequency	50/60Hz
	Rated breaking capacity	10,000A
	Energy limiting class	3
	Rated impulse withstand voltage(1.5/50) $U_{imp}$	4,000V
	Dielectric test voltage at ind. Freq. for 1 min	2kV
	Pollution degree	2
Thermo-magnetic release characteristic	B,C,D	
<b>Mechanical Features</b>	Electrical life	8,000 Cycles
	Mechanical life	20,000 Cycles
	Contact position indicator	Yes
	Protection degree	IP20
	Reference temperature for setting of thermal element	30°C
	Ambient temperature (with daily average $\leq 35^\circ\text{C}$ )	-5°C~+40°C
	Storage temperature	-25°C~+70°C
<b>Installation</b>	Terminal connection type	Cable/Pin-type busbar/U-type busbar
	Terminal size top/bottom for cable	25mm <sup>2</sup> 18-3AWG
	Terminal size top/bottom for busbar	25mm <sup>2</sup> 18-3AWG
	Tightening torque	2.5Nm 22In-lbs
	Mounting	On DIN rail EN60715(35mm) by means of fast clip device
	Connection	From top and bottom
<b>Combination with accessories</b>	Auxiliary contact	EKM1-OF
	Alarm contact	EKM1-FB
	Shunt release	EKM1-MX
	Over/Under voltage release	EKM1-MV+MN

# EKM1-63H 10KA MCB

Mini Circuit Breaker



Standard\_ IEC60898-1

## MCB Characteristics

### Characteristics Curves

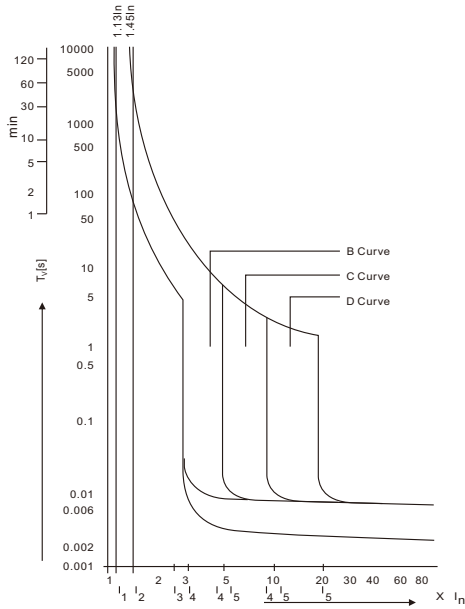

As per IEC60898	Thermal Tripping		Magnetic Tripping			
	No tripping current	Tripping current $I_2$	Time Limits t	Hold current $I_4$	Trip current $I_5$	Time Limits t
B Curve	$1.13 \times I_N$	$1.45 \times I_N$	$\geq 1h$ $< 1h$	$3 \times I_N$	$5 \times I_N$	$\geq 0.1s$ $< 0.1s$
C Curve	$1.13 \times I_N$	$1.45 \times I_N$	$\geq 1h$ $< 1h$	$5 \times I_N$	$10 \times I_N$	$\geq 0.1s$ $< 0.1s$
D Curve	$1.13 \times I_N$	$1.45 \times I_N$	$\geq 1h$ $< 1h$	$10 \times I_N$	$20 \times I_N$	$\geq 0.1s$ $< 0.1s$

### Tripping characteristics

Based on the Tripping Characteristics, MCB are available in “B”, “C” and “D” curve to suit different types of applications.

“B” Curve for protection of electrical circuits with equipment that does not cause surge current (lighting and distribution circuits) Short circuit release is set to (3-5)In.

“C” Curve for protection of electrical circuits with equipment that cause surge current (inductive loads and motor circuits) Short circuit release is set to (5-10)In.

“D” Curve for protection of electrical circuits with cause high inrush current, typically 12-15 times the thermal rated current (transformes, x-ray machines etc,) Short circuit release is set to (10-20)In.

### Circuit Diagram

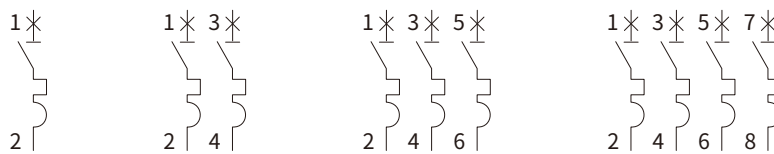

## Overall and Installation Dimension(mm)

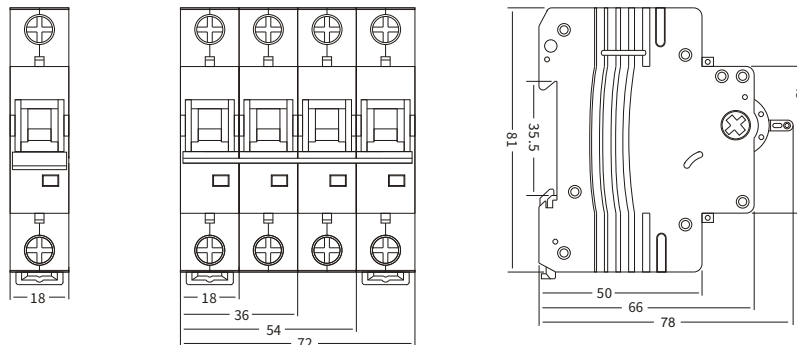

# EKM1-63DC 6KA/10KA DC MCB

Mini Circuit Breaker

**ETEK**<sup>®</sup>

Standard\_ IEC60947-2



## Technical Data

<b>Electrical Features</b>	Rated current $I_n$	1,2,3,4,5,6,8,10,13,16,20,25,32,40,50,63A
	Poles	1P, 2P, 4P
	Rated voltage $U_e$	1P(250V), 2P(500V), 4P(1000V)
	Rated breaking capacity	6,000/10,000A
	Rated impulse withstand voltage(1.5/50) $U_{imp}$	4,000V
	Dielectric test voltage at ind. Freq. for 1 min	2kV
	Pollution degree	2
	Thermo-magnetic release characteristic	C (7~10) $I_n$
<b>Mechanical Features</b>	Electrical life	4,000 Cycles
	Mechanical life	10,000 Cycles
	Contact position indicator	Yes
	Protection degree	IP20
	Reference temperature for setting of thermal element	30°C
	Ambient temperature (with daily average $\leq 35^\circ\text{C}$ )	-5°C~+40°C
	Storage temperature	-25°C~+70°C
<b>Installation</b>	Terminal connection type	Cable/Pin-type busbar/U-type busbar
	Terminal size top/bottom for cable	25mm <sup>2</sup> 18-3AWG
	Terminal size top/bottom for busbar	25mm <sup>2</sup> 18-3AWG
	Tightening torque	2.5Nm 22In-lbs
	Mounting	On DIN rail EN60715(35mm) by means of fast clip device
	Connection	According to the wiring diagram
<b>Combination with accessories</b>	Auxiliary contact	EKM1-OF
	Alarm contact	EKM1-FB
	Shunt release	EKM1-MX
	Over/Under voltage release	EKM1-MV+MN

# EKM1-63DC 6KA/10KA DC MCB

Mini Circuit Breaker



Standard\_ IEC60947-2

## MCB Characteristics

### Characteristics Curves

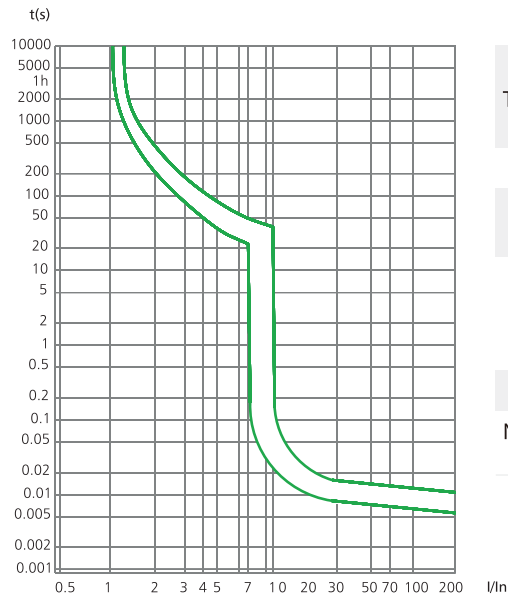

Test	Test current	Initial state	Time limit for tripping or not tripping	Expected result	Remarks
a	1.05In	Cold state a	$t \leq 1h$	Not tripping	
b	1.30In	Right after test number a	$t < 1h$	Tripping	The current is rising within 5s
c	7In	Cold state a	$0.2s < t < 15s$ ( $I_n \leq 32A$ ) $0.2s < t \leq 30s$ ( $I_n > 32A$ )	Tripping	
d	10In	Cold state a	$t < 0.1s$	Tripping	

Note: The terminology "Cold state" means that the test is performed at the base calibration temperature with no load prior to the test.

### Circuit Diagram

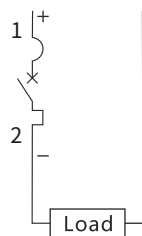

1P

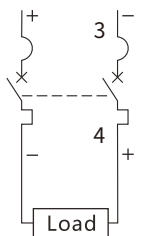

2P

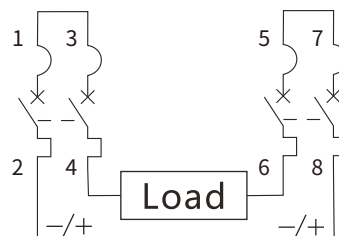

4P

## Overall and Installation Dimension(mm)

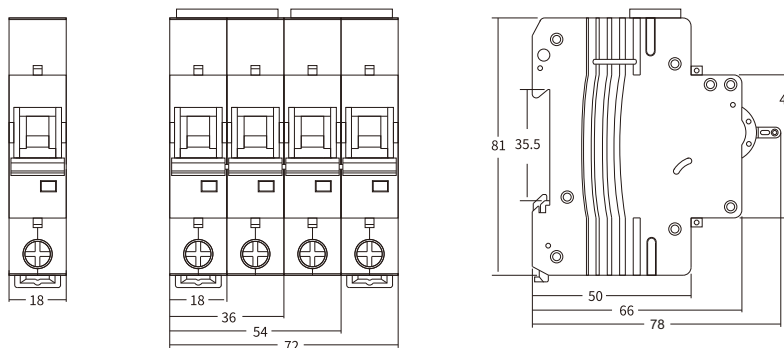

# EKM1-40N 6KA MCB

Mini Circuit Breaker

**ETEK**<sup>®</sup>

Standard\_ IEC60898-1



## Technical Data

<b>Electrical Features</b>	Rated current $I_n$	6,8,10,13,16,20,25,32,40A
	Poles	1P+N
	Rated voltage $U_e$	230/240V~
	Insulation voltage $U_i$	500V
	Rated frequency	50/60Hz
	Rated breaking capacity	6,000A
	Energy limiting class	3
	Rated impulse withstand voltage(1.5/50) $U_{imp}$	4,000V
	Dielectric test voltage at ind. Freq. for 1 min	2kV
	Pollution degree	2
Thermo-magnetic release characteristic	B,C	
<b>Mechanical Features</b>	Electrical life	4,000 Cycles
	Mechanical life	10,000 Cycles
	Contact position indicator	Yes
	Protection degree	IP20
	Reference temperature for setting of thermal element	30°C
	Ambient temperature (with daily average $\leq 35^\circ\text{C}$ )	-5°C~+40°C
	Storage temperature	-25°C~+70°C
<b>Installation</b>	Terminal connection type	Cable/Pin-type busbar
	Terminal size top/bottom for cable	16mm <sup>2</sup> 18-5AWG
	Terminal size top/bottom for busbar	16mm <sup>2</sup> 18-5AWG
	Tightening torque	1.5Nm 14In-lbs
	Mounting	On DIN rail EN60715(35mm) by means of fast clip device
	Connection	From top and bottom
<b>Combination with accessories</b>	Auxiliary contact	EKM1-OF
	Alarm contact	EKM1-FB
	Shunt release	EKM1-MX
	Over/Under voltage release	EKM1-MV+MN



# EKM1-40N 6KA MCB

Mini Circuit Breaker



Standard\_ IEC60898-1

## MCB Characteristics

### Characteristics Curves

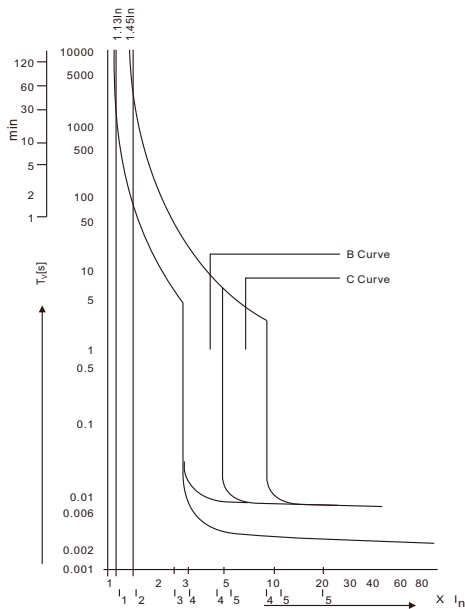

As per IEC60898	Thermal Tripping		Magnetic Tripping			
	No tripping current	Tripping current $I_2$	Time Limits t	Hold current $I_4$	Trip current $I_5$	Time Limits t
B Curve	$1.13 \times I_N$	$1.45 \times I_N$	$\geq 1h$ $< 1h$	$3 \times I_N$	$5 \times I_N$	$\geq 0.1s$ $< 0.1s$
C Curve	$1.13 \times I_N$	$1.45 \times I_N$	$\geq 1h$ $< 1h$	$5 \times I_N$	$10 \times I_N$	$\geq 0.1s$ $< 0.1s$

### Tripping characteristics

Based on the Tripping Characteristics, MCB are available in “B”, “C” and “D” curve to suit different types of applications.

“B” Curve for protection of electrical circuits with equipment that does not cause surge current (lighting and distribution circuits) Short circuit release is set to (3-5)In.

“C” Curve for protection of electrical circuits with equipment that cause surge current (inductive loads and motor circuits) Short circuit release is set to (5-10)In.

### Circuit Diagram



## Overall and Installation Dimension(mm)

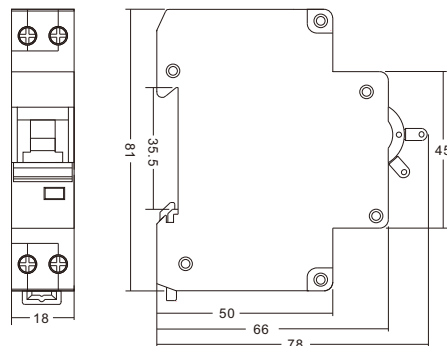

# EKM1-125 10KA MCB

Mini Circuit Breaker

**ETЭК**<sup>®</sup>

Standard\_ IEC60947-2



## Technical Data

<b>Electrical Features</b>	Rated current $I_n$	63,80,100,125A
	Poles	1P,1P+N,2P,3P,3P+N,4P
	Rated voltage $U_e$	240/415V~
	Insulation voltage $U_i$	500V
	Rated frequency	50/60Hz
	Rated breaking capacity	10,000A
	Energy limiting class	3
	Rated impulse withstand voltage(1.5/50) $U_{imp}$	4,000V
	Dielectric test voltage at ind. Freq. for 1 min	2kV
	Pollution degree	2
Thermo-magnetic release characteristic	8-12 $I_n$	
<b>Mechanical Features</b>	Electrical life	4,000 Cycles
	Mechanical life	10,000 Cycles
	Contact position indicator	Yes
	Protection degree	IP20
	Reference temperature for setting of thermal element	30°C
	Ambient temperature (with daily average $\leq 35^\circ\text{C}$ )	-5°C~+40°C
	Storage temperature	-25°C~+70°C
<b>Installation</b>	Terminal connection type	Cable/Pin-type busbar
	Terminal size top/bottom for cable	50mm <sup>2</sup> 18-2AWG
	Terminal size top/bottom for busbar	50mm <sup>2</sup> 18-2AWG
	Tightening torque	3.5Nm 30In-lbs
	Mounting	On DIN rail EN60715(35mm) by means of fast clip device
	Connection	From top and bottom

# EKM1-125 10KA MCB

Mini Circuit Breaker



Standard\_ IEC60947-2

## MCB Characteristics

Characteristics  
Curves

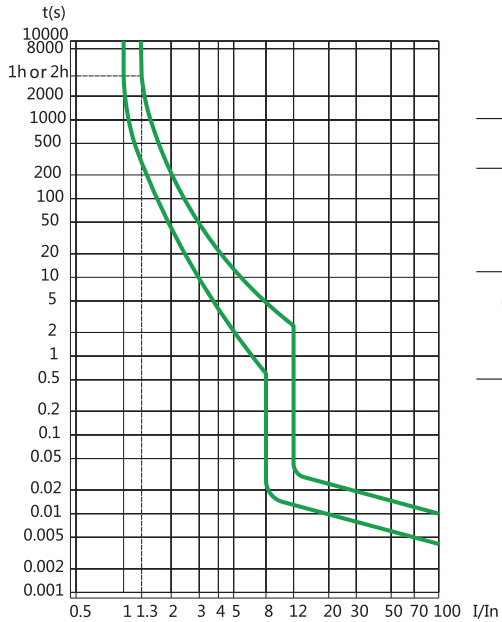

As per IEC60947	Thermal Tripping		Magnetic Tripping			
	No tripping current	Tripping current $I_2$	Time Limits t	Hold current $I_4$	Trip current $I_5$	Time Limits t
63-125A	$1.05 \times I_N$		$\geq 2h$ $< 1h$	$8 \times I_N$		$\geq 0.2s$ $< 0.2s$
		$1.30 \times I_N$			$12 \times I_N$	

Circuit  
Diagram

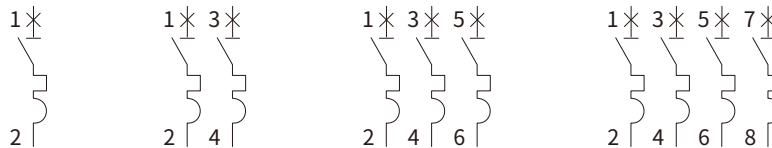

## Overall and Installation Dimension(mm)

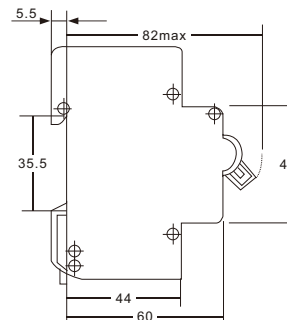
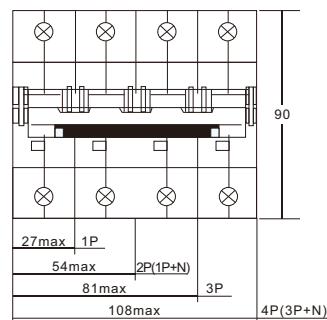

# EKL1-63 6KA RCCB EKL1-63H 10KA RCCB



Residual Current Circuit Breaker

**ETEK**<sup>®</sup>

Standard\_ IEC61008-1



## Technical Data

<b>Electrical Features</b>	Mode	Electromagnetic
	Type	AC,A,G,S
	Rated current In	16,25,32,40,63A
	Poles	2P(1P+N),4P(3P+N)
	Rated voltage Ue	2P 240V~
		4P 415V~
	Insulation voltage Ui	500V
	Rated frequency	50/60Hz
	Rated residual operation current(I $\Delta$ n)	10,30,100,300mA
	Rated residual making and breaking capacity (I $\Delta$ m)	500(In=16-40A) 630(In=63A)
	Short-circuit current Inc= I $\Delta$ c	EKL1-63 6,000A
		EKL1-63H 10,000A
	SCPD fuse	EKL1-63  6000
		EKL1-63H  10000
	Break time under I $\Delta$ n	≤0.1s
	Rated impulse withstand voltage(1.5/50) Uimp	4000V
	Dielectric test voltage at ind.Freq. for 1min	2.5kV
Electrical life	2,000 Cycles	
Mechanical life	4,000 Cycles	
<b>Installation</b>	Contact position indicator	Yes
	Protection degree	IP20
	Ambient temperature(with daily average≤35°C)	-5°C~+40°C
	Storage temperature	-25°C~+70°C
	Terminal connection type	Cable/Pin-type busbar/U-type busbar
	Terminal size top/bottom for cable	25mm <sup>2</sup> 18-3AWG
	Terminal size top/bottom for busbar	25mm <sup>2</sup> 18-3AWG
	Tightening torque	2.5Nm 22In-lbs
Mounting	On DIN rail EN60715(35mm) by means of fast clip device	
Connection	From top and bottom	

# EKL1-63 6KA RCCB EKL1-63H 10KA RCCB



Residual Current Circuit Breaker



Standard\_ IEC61008-1

Tripping  
Current  
Range

Type	Tripping current I $\Delta$ /A		
AC	0.5I $\Delta$ n < I $\Delta$ < I $\Delta$ n		
A	Lagging Angle	I $\Delta$ n > 0.01A	I $\Delta$ n $\leq$ 0.01A
	0°	0.35I $\Delta$ n $\leq$ I $\Delta$ $\leq$ 1.4I $\Delta$ n	0.35I $\Delta$ n $\leq$ I $\Delta$ $\leq$ 2I $\Delta$ n
	90°	0.25I $\Delta$ n $\leq$ I $\Delta$ $\leq$ 1.4I $\Delta$ n	0.25I $\Delta$ n $\leq$ I $\Delta$ $\leq$ 2I $\Delta$ n
	135°	0.11I $\Delta$ n $\leq$ I $\Delta$ $\leq$ 1.4I $\Delta$ n	0.11I $\Delta$ n $\leq$ I $\Delta$ $\leq$ 2I $\Delta$ n

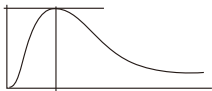
Alternative Current Sensitive	Pulsating direct current sensitive	Surge current proof
		
They react to AC current which, whether suddenly applied or slowly arising.	They react to AC and pulsating DC fault current which reach 0 or almost 0 within one time period of the mains frequency.	RCCB' s surge capacity. Not tripping at standardized 8/20 us surge-current waves acc.to VDE 0432 Part 2 with surge current values of up to 250A.

Circuit  
Diagram

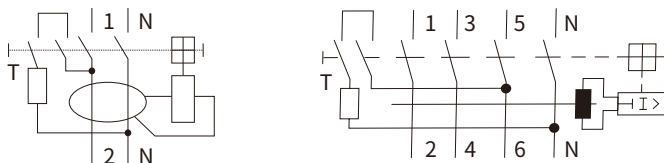

## Overall and Installation Dimension(mm)

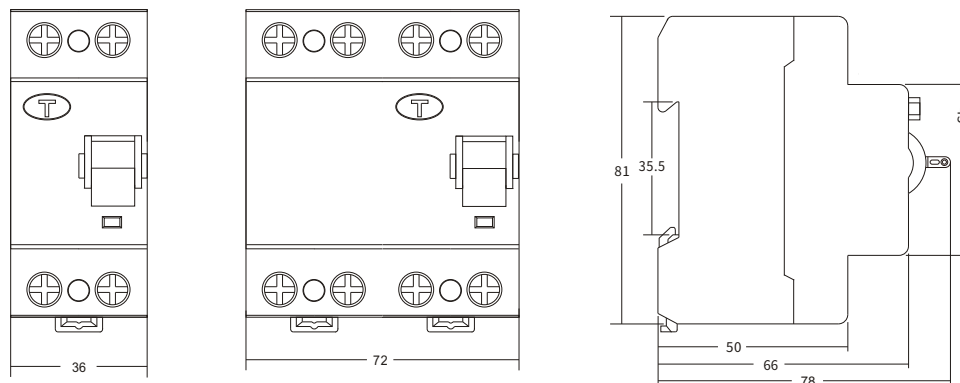

# EKL1-63B 10KA B Type RCCB

Residual Current Circuit Breaker

**ETEK**<sup>®</sup>

Standard\_ IEC61008-1  
IEC62423



## Technical Data

Electrical Features	Mode	Electromagnetic
	Type(wave form of the earth leakage sensed)	B
	Rated current In	25,40,63A
	Poles	4P
	Rated voltage Ue	4P 415V~
	Insulation voltage Ui	500V
	Rated frequency	50/60Hz
	Rated residual operation current(I $\Delta$ n)	30mA
	Rated residual making and breaking capacity (I $\Delta$ m)	500(In=2540A) 630(In=63A)
	Short-circuit current Inc= I $\Delta$ c	10,000A
	SCPD fuse	 10000
	Break time under I $\Delta$ n	≤0.1s
	Rated impulse withstand voltage(1.5/50) Uimp	4000V
	Dielectric test voltage at ind.Freq. for 1min	2.5kV
	Electrical life	2,000 Cycles
	Mechanical life	4,000 Cycles

Installation	Contact position indicator	Yes
	Protection degree	IP20
	Ambient temperature(with daily average ≤35°C)	-5°C~+40°C
	Storage temperature	-25°C~+70°C
	Terminal connection type	Cable/Pin-type busbar/U-type busbar
	Terminal size top/bottom for cable	25mm <sup>2</sup> 18-3AWG
	Terminal size top/bottom for busbar	25mm <sup>2</sup> 18-3AWG
	Tightening torque	2.5Nm 22In-lbs
	Mounting	On DIN rail EN60715(35mm) by means of fast clip device
	Connection	From top and bottom

# EKL1-63B 10KA B Type RCCB

Residual Current Circuit Breaker



Standard\_ IEC61008-1  
IEC62423

Tripping Current Range	Lagging Angle	$I_{\Delta n} > 0.01A$	$I_{\Delta n} \leq 0.01A$
	0°	$0.35I_{\Delta n} \leq I_{\Delta} \leq 1.4I_{\Delta n}$	$0.35I_{\Delta n} \leq I_{\Delta} \leq 2I_{\Delta n}$
	90°	$0.25I_{\Delta n} \leq I_{\Delta} \leq 1.4I_{\Delta n}$	$0.25I_{\Delta n} \leq I_{\Delta} \leq 2I_{\Delta n}$
	135°	$0.11I_{\Delta n} \leq I_{\Delta} \leq 1.4I_{\Delta n}$	$0.11I_{\Delta n} \leq I_{\Delta} \leq 2I_{\Delta n}$

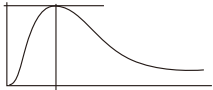
Detectable wave form	Pulsating direct current sensitive	Surge current proof
<p>B class</p> <p>Tripping is ensured for sinusoidal AC residual currents, pulsed DC residual currents, alternating residual sinusoidal currents up to 1000Hz, pulsating direct residual currents and for smooth direct residual currents, whether applied suddenly or increasing slowly.</p>	 <p>They react to AC and pulsating DC fault current which reach 0 or almost 0 within one time period of the mains frequency.</p>	 <p>RCCB's surge capacity. Not tripping at standardized 8/20 us surge-current waves acc.to VDE 0432 Part 2 with surge current values of up to 250A.</p>

## Circuit Diagram

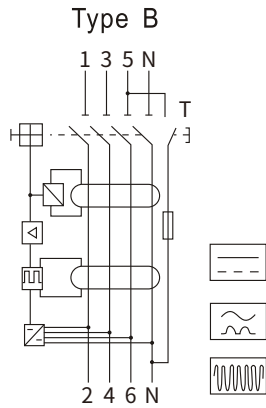

## Overall and Installation Dimension(mm)

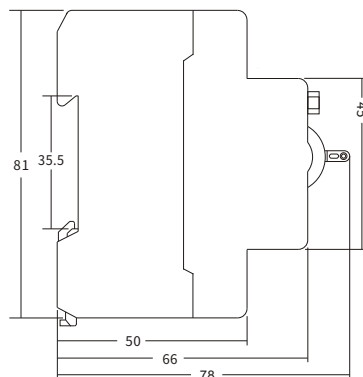
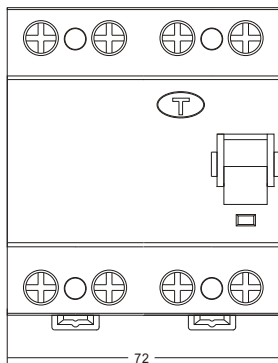

# EKL2-40 6KA RCBO

RCCB with Overcurrent Protection

**ETEK**<sup>®</sup>

Standard\_ IEC61009-1



## Technical Data

<b>Electrical Features</b>	Mode	Electronic
	Type	AC,A
	Rated current I <sub>n</sub>	6,8,10,13,16,20,25,32,40A
	Poles	1P+N
	Rated voltage U <sub>e</sub>	240V~
	Insulation voltage U <sub>i</sub>	500V
	Rated frequency	50/60Hz
	Rated residual operating current(I $\Delta$ n)	10,30,100,300mA
	Break time under I $\Delta$ n	≤0.1s
	Rated breaking capacity	6,000A
	Energy limiting class	3
	Rated impulse withstand voltage(1.5/50) U <sub>imp</sub>	4,000V
	Dielectric test voltage at ind.Freq. for 1min	2kV
	Pollution degree	2
Thermo-magnetic release characteristic	B,C	
<b>Mechanical Features</b>	Electrical life	4,000 Cycles
	Mechanical life	10,000 Cycles
	Contact position indicator	Yes
	Protection degree	IP20
	Reference temperature for setting of thermal element	30°C
	Ambient temperature (with daily average ≤35°C)	-5°C~+40°C
	Storage temperature	-25°C~+70°C
<b>Installation</b>	Terminal connection type	Cable/Pin-type busbar/U-type busbar
	Terminal size top/bottom for cable	25mm <sup>2</sup> 18-3AWG
	Terminal size top/bottom for busbar	25mm <sup>2</sup> 18-3AWG
	Tightening torque	2.5Nm 22In-lbs
	Mounting	On DIN rail EN60715(35mm) by means of fast clip device
	Connection	From top
<b>Specialfunction can customized</b>	Over voltage protection	Yes
	Under voltage protection	Yes
	Over/Under voltage protection	Yes



# EKL2-40 6KA RCBO

RCCB with Overcurrent Protection



Standard\_ IEC61009-1

## Characteristics

Tripping Current Range	Type	Tripping current $I\Delta/A$		
	AC		$0.5I\Delta_n < I\Delta < I\Delta_n$	
A	Lagging Angle	$I\Delta_n > 0.01A$	$I\Delta_n \leq 0.01A$	
		0°	$0.35I\Delta_n \leq I\Delta \leq 1.4I\Delta_n$	$0.35I\Delta_n \leq I\Delta \leq 2I\Delta_n$
		90°	$0.25I\Delta_n \leq I\Delta \leq 1.4I\Delta_n$	$0.25I\Delta_n \leq I\Delta \leq 2I\Delta_n$
	135°	$0.11I\Delta_n \leq I\Delta \leq 1.4I\Delta_n$	$0.11I\Delta_n \leq I\Delta \leq 2I\Delta_n$	

## Characteristics Curves

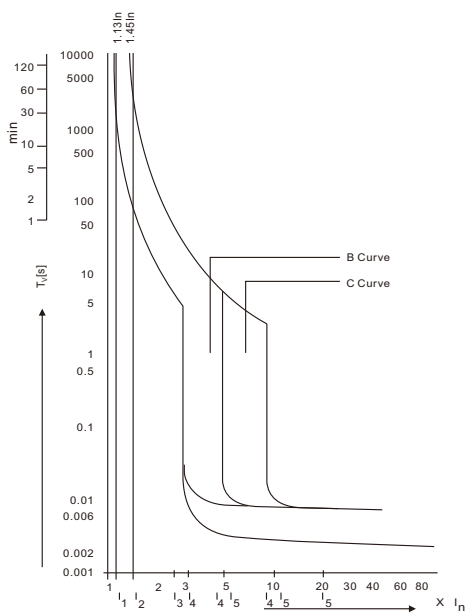

Thermal Tripping				Magnetic Tripping		
As per IEC60898	No tripping current	Tripping current $I_2$	Time Limits t	Hold current $I_4$	Trip current $I_5$	Time Limits t
B Curve	$1.13 \times I_N$	$\geq 1h$	$\geq 1h$	$3 \times I_N$	$\geq 0.1s$	$\geq 0.1s$
		$< 1h$	$< 1h$			$5 \times I_N$
C Curve	$1.13 \times I_N$	$\geq 1h$	$\geq 1h$	$5 \times I_N$	$\geq 0.1s$	$\geq 0.1s$
		$< 1h$	$< 1h$			$10 \times I_N$

## Circuit Diagram

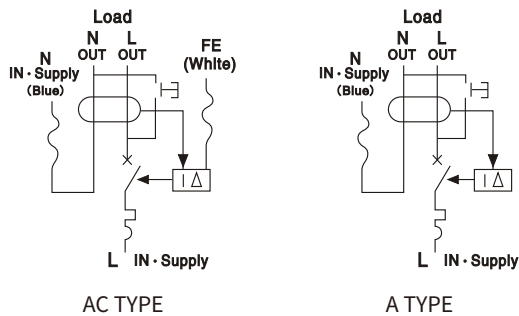

## Overall and Installation Dimension (mm)

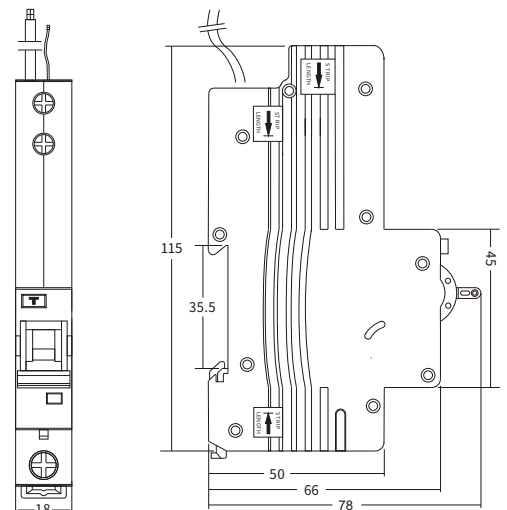

# EKL3-40 6KA RCBO

RCCB with Overcurrent Protection



Standard\_ IEC61009-1



## Technical Data

<b>Electrical Features</b>	Mode	Electronic
	Type	AC,A
	Rated current I <sub>n</sub>	6,8,10,13,16,20,25,32,40A
	Poles	1P+N
	Rated voltage U <sub>e</sub>	230/240V~
	Insulation voltage U <sub>i</sub>	500V
	Rated frequency	50/60Hz
	Rated residual operating current(I <sub>Δn</sub> )	10,30,100,300mA
	Break time under I <sub>Δn</sub>	≤0.1s
	Rated breaking capacity	6,000A
	Energy limiting class	3
	Rated impulse withstand voltage(1.5/50) U <sub>imp</sub>	4,000V
	Dielectric test voltage at ind.Freq. for 1min	2kV
	Pollution degree	2
Thermo-magnetic release characteristic	B,C	
<b>Mechanical Features</b>	Electrical life	4,000 Cycles
	Mechanical life	10,000 Cycles
	Contact position indicator	Yes
	Protection degree	IP20
	Reference temperature for setting of thermal element	30°C
	Ambient temperature (with daily average ≤35°C)	-5°C~+40°C
	Storage temperature	-25°C~+70°C
<b>Installation</b>	Terminal connection type	Cable/Pin-type busbar/U-type busbar
	Terminal size top/bottom for cable	25mm <sup>2</sup> 18-3AWG
	Terminal size top/bottom for busbar	25mm <sup>2</sup> 18-3AWG
	Tightening torque	2.5Nm 22In-lbs
	Mounting	On DIN rail EN60715(35mm) by means of fast clip device
	Connection	From top and bottom
<b>Combination with accessories</b>	Auxiliary contact	EKM1-OF
	Alarm contact	EKM1-FB
	Shunt release	EKM1-MX
<b>Combination with accessories</b>	Over voltage protection	Yes
	Under voltage protection	Yes
	Over/Under voltage protection	Yes

# EKL3-40 6KA RCBO

RCCB with Overcurrent Protection



Standard\_ IEC61009-1

## Characteristics

Tripping Current Range	Type	Tripping current $I\Delta/A$		
	AC		$0.5I\Delta_n < I\Delta < I\Delta_n$	
A	Lagging Angle		$I\Delta_n > 0.01A$	$I\Delta_n \leq 0.01A$
		0°	$0.35I\Delta_n \leq I\Delta \leq 1.4I\Delta_n$	$0.35I\Delta_n \leq I\Delta \leq 2I\Delta_n$
		90°	$0.25I\Delta_n \leq I\Delta \leq 1.4I\Delta_n$	$0.25I\Delta_n \leq I\Delta \leq 2I\Delta_n$
		135°	$0.11I\Delta_n \leq I\Delta \leq 1.4I\Delta_n$	$0.11I\Delta_n \leq I\Delta \leq 2I\Delta_n$

## Characteristics Curves

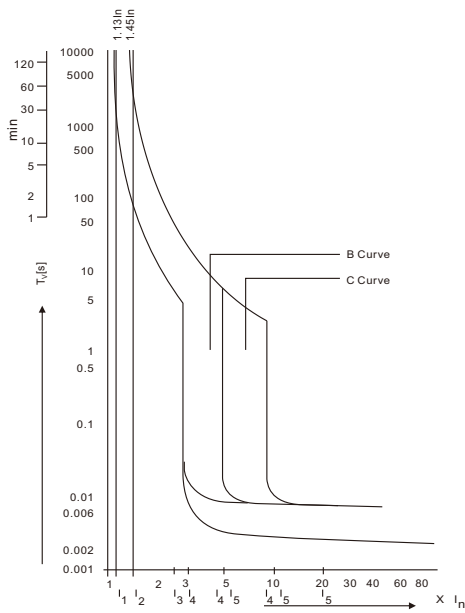

As per IEC60898	Thermal Tripping		Magnetic Tripping			
	No tripping current	Tripping current $I_2$	Time Limits $t$	Hold current $I_4$	Trip current $I_5$	Time Limits $t$
B Curve	$1.13 \times I_N$		$\geq 1h$	$3 \times I_N$		$\geq 0.1s$
		$1.45 \times I_N$	$< 1h$			$5 \times I_N$
C Curve	$1.13 \times I_N$		$\geq 1h$	$5 \times I_N$		$\geq 0.1s$
		$1.45 \times I_N$	$< 1h$			$10 \times I_N$

## Circuit Diagram

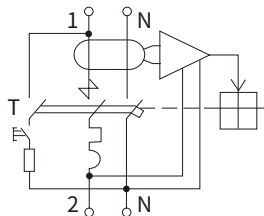

## Overall and Installation Dimension (mm)

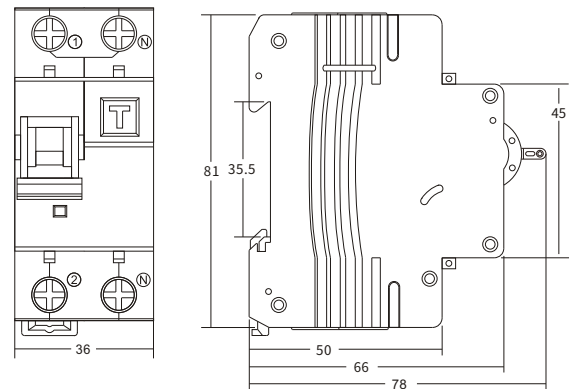

# EKL3-40M 6KA RCBO (Electromagnetic Type)

RCCB with Overcurrent Protection



Standard\_ IEC61009-1



## Technical Data

<b>Electrical Features</b>	Mode	Electromagnetic
	Type	AC,A
	Rated current I <sub>n</sub>	6,8,10,13,16,20,25,32,40A
	Poles	1P+N
	Rated voltage U <sub>e</sub>	230/240V~
	Insulation voltage U <sub>i</sub>	500V
	Rated frequency	50/60Hz
	Rated residual operating current(I <sub>Δn</sub> )	30,100,300mA
	Break time under I <sub>Δn</sub>	≤0.1s
	Rated breaking capacity	6,000A
	Energy limiting class	3
	Rated impulse withstand voltage(1.5/50) U <sub>imp</sub>	4,000V
	Dielectric test voltage at ind.Freq. for 1min	2kV
	Pollution degree	2
Thermo-magnetic release characteristic	B,C	
<b>Mechanical Features</b>	Electrical life	4,000 Cycles
	Mechanical life	10,000 Cycles
	Contact position indicator	Yes
	Protection degree	IP20
	Reference temperature for setting of thermal element	30°C
	Ambient temperature (with daily average ≤35°C)	-5°C~+40°C
	Storage temperature	-25°C~+70°C
<b>Installation</b>	Terminal connection type	Cable/Pin-type busbar/U-type busbar
	Terminal size top/bottom for cable	25mm <sup>2</sup> 18-3AWG
	Terminal size top/bottom for busbar	25mm <sup>2</sup> 18-3AWG
	Tightening torque	2.5Nm 22In-lbs
	Mounting	On DIN rail EN60715(35mm) by means of fast clip device
	Connection	From top and bottom
<b>Combination with accessories</b>	Auxiliary contact	EKM1-OF
	Alarm contact	EKM1-FB
	Shunt release	EKM1-MX

# EKL3-40M 6KA RCBO (Electromagnetic Type)

RCCB with Overcurrent Protection

Standard\_ IEC61009-1

## Characteristics

Tripping Current Range	Type	Tripping current $I\Delta/A$		
	AC		$0.5I\Delta n < I\Delta < I\Delta n$	
A	Lagging Angle	$I\Delta n > 0.01A$		$I\Delta n \leq 0.01A$
		0°	$0.35I\Delta n \leq I\Delta \leq 1.4I\Delta n$	$0.35I\Delta n \leq I\Delta \leq 2I\Delta n$
		90°	$0.25I\Delta n \leq I\Delta \leq 1.4I\Delta n$	$0.25I\Delta n \leq I\Delta \leq 2I\Delta n$
		135°	$0.11I\Delta n \leq I\Delta \leq 1.4I\Delta n$	$0.11I\Delta n \leq I\Delta \leq 2I\Delta n$

## Characteristics Curves

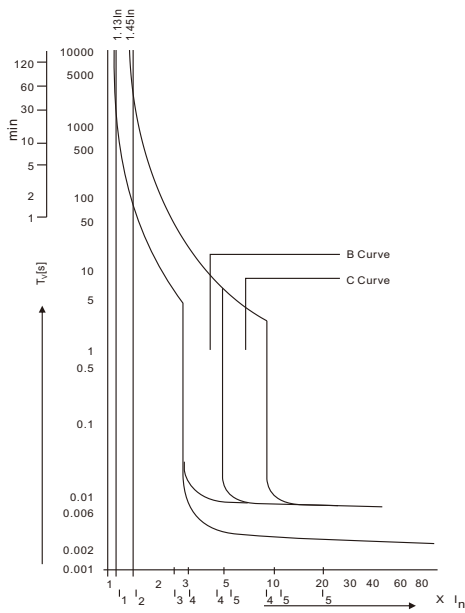

As per IEC60898	Thermal Tripping		Magnetic Tripping			
	No tripping current	Tripping current $I_2$	Time Limits t	Hold current $I_4$	Trip current $I_5$	Time Limits t
B Curve	$1.13 \times I_N$		$\geq 1h$	$3 \times I_N$		$\geq 0.1s$
		$1.45 \times I_N$	$< 1h$		$5 \times I_N$	$< 0.1s$
C Curve	$1.13 \times I_N$		$\geq 1h$	$5 \times I_N$		$\geq 0.1s$
		$1.45 \times I_N$	$< 1h$		$10 \times I_N$	$< 0.1s$

## Circuit Diagram

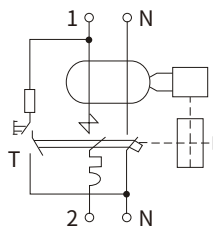

## Overall and Installation Dimension (mm)

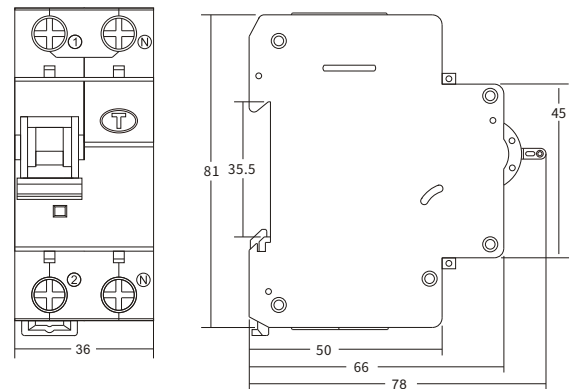

# EKL5-63 6KA RCBO

RCCB with Overcurrent Protection

**ETEK**<sup>®</sup>

Standard\_ IEC61009-1



## Technical Data

<b>Electrical Features</b>	Mode	Electronic
	Type	AC,A,S
	Rated current I <sub>n</sub>	6,8,10,13,16,20,25,32,40,50,63A
	Poles	2P(1P+N),4P(3P+N)
	Rated voltage U <sub>e</sub>	2P 240V~
		4P 415V~
	Insulation voltage U <sub>i</sub>	500V
	Rated frequency	50/60Hz
	Rated residual operating current(I <sub>Δn</sub> )	10,30,100,300mA
	Break time under I <sub>Δn</sub>	≤0.1s(S type <0.5s)
	Rated breaking capacity	6,000A
	Energy limiting class	3
	Rated impulse withstand voltage(1.5/50) U <sub>imp</sub>	4,000V
	Dielectric test voltage at ind.Freq. for 1min	2kV
Pollution degree	2	
Thermo-magnetic release characteristic	B,C,D	
<b>Mechanical Features</b>	Electrical life	4,000 Cycles
	Mechanical life	10,000 Cycles
	Contact position indicator	Yes
	Protection degree	IP20
	Reference temperature for setting of thermal element	30°C
	Ambient temperature (with daily average ≤35°C)	-5°C~+40°C
	Storage temperature	-25°C~+70°C
<b>Installation</b>	Terminal connection type	Cable/Pin-type busbar/U-type busbar
	Terminal size top/bottom for cable	25mm <sup>2</sup> 18-3AWG
	Terminal size top/bottom for busbar	25mm <sup>2</sup> 18-3AWG
	Tightening torque	2.5Nm 22In-lbs
	Mounting	On DIN rail EN60715(35mm) by means of fast clip device
	Connection	From top
<b>Combination with accessories</b>	Auxiliary contact	EKM1-OF
	Alarm contact	EKM1-FB
	Shunt release	EKM1-MX
<b>Combination with accessories</b>	Over voltage protection	Yes
	Under voltage protection	Yes
	Over/Under voltage protection	Yes

# EKL5-63 6KA RCBO

RCCB with Overcurrent Protection



Standard\_ IEC61009-1

## Characteristics

Tripping Current Range	Type	Tripping current $I\Delta/A$	
	AC		$0.5I\Delta n < I\Delta < I\Delta n$
A	Lagging Angle	$I\Delta n > 0.01A$	
	0°	$0.35I\Delta n \leq I\Delta \leq 1.4I\Delta n$	$I\Delta n \leq 0.01A$ $0.35I\Delta n \leq I\Delta \leq 2I\Delta n$
	90°	$0.25I\Delta n \leq I\Delta \leq 1.4I\Delta n$	$0.25I\Delta n \leq I\Delta \leq 2I\Delta n$
	135°	$0.11I\Delta n \leq I\Delta \leq 1.4I\Delta n$	$0.11I\Delta n \leq I\Delta \leq 2I\Delta n$

## Characteristics Curves

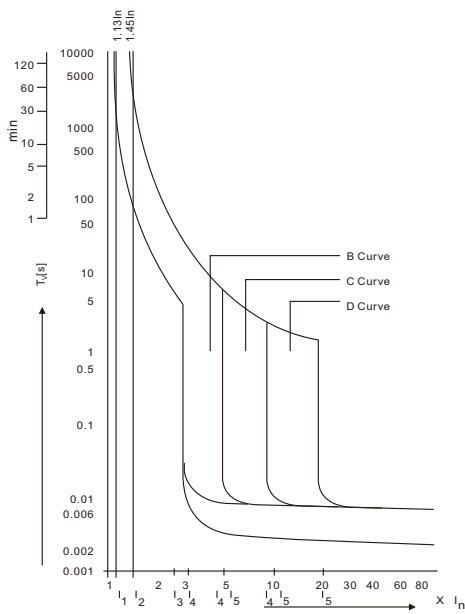

As per IEC60898	Thermal Tripping		Magnetic Tripping			
	No tripping current	Tripping current $I_2$	Time Limits t	Hold current $I_4$	Trip current $I_5$	Time Limits t
B Curve	$1.13 \times I_N$	$1.45 \times I_N$	$\geq 1h$ $< 1h$	$3 \times I_N$	$5 \times I_N$	$\geq 0.1s$ $< 0.1s$
C Curve	$1.13 \times I_N$	$1.45 \times I_N$	$\geq 1h$ $< 1h$	$5 \times I_N$	$10 \times I_N$	$\geq 0.1s$ $< 0.1s$
D Curve	$1.13 \times I_N$	$1.45 \times I_N$	$\geq 1h$ $< 1h$	$10 \times I_N$	$20 \times I_N$	$\geq 0.1s$ $< 0.1s$

## Circuit Diagram

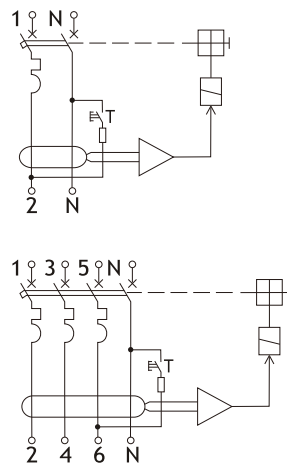

## Overall and Installation Dimension (mm)

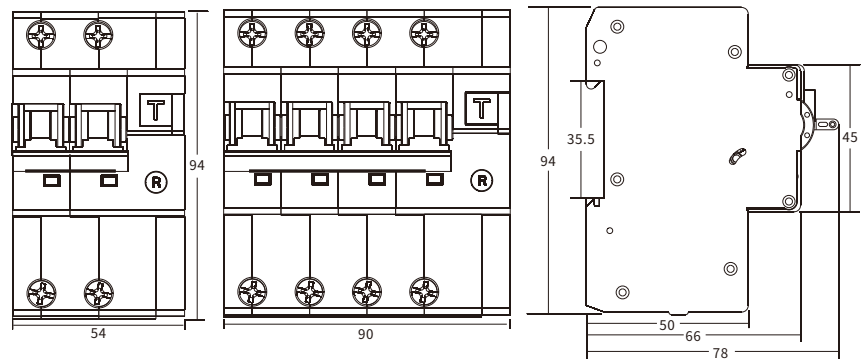



### Technical Data

<b>Electrical Features</b>	Rated current $I_n$	32,40,50,63,80,100,125A
	Poles	1P,2P,3P,4P
	Rated voltage $U_e$	240/415V~
	Insulation voltage $U_i$	500V
	Rated frequency	50/60Hz
	Rated short-time withstand current $I_{cw}$	12I <sub>e</sub> ,1s
	Rated making and breaking capacity	3I <sub>e</sub> ,1.05U <sub>e</sub> ,cos φ=0.65
	Rated short circuit making capacity	20I <sub>e</sub> ,t=0.1s
	Rated impulse withstand voltage(1.5/50) $U_{imp}$	4,000V
	Dielectric test voltage at ind.Freq. for 1min	2.5kV
Utilization category	AC-22A	
<b>Mechanical Features</b>	Electrical life	4,000 Cycles
	Mechanical life	10,000 Cycles
	Contact position indicator	Yes
	Protection degree	IP20
<b>Installation</b>	Terminal connection type	Cable/Pin-type busbar/U-type busbar
	Terminal size top/bottom for cable	50mm <sup>2</sup> 18-2AWG
	Terminal size top/bottom for busbar	50mm <sup>2</sup> 18-2AWG
	Tightening torque	3.5Nm 30In-lbs
	Mounting	On DIN rail EN60715(35mm) by means of fast clip device
	Connection	From top and bottom

### Overall and Installation Dimension(mm)

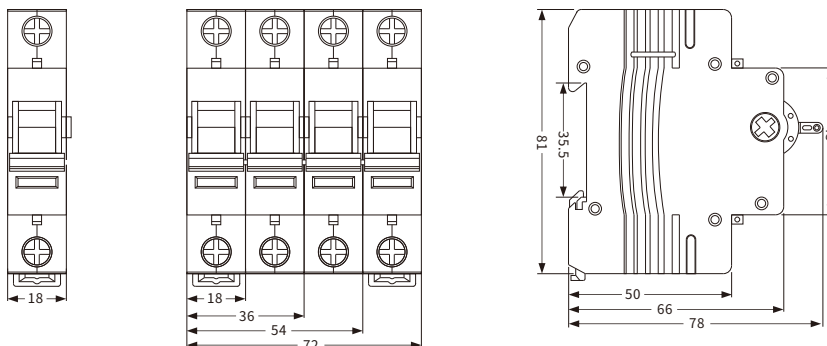



**EKM1-OF** Auxiliary Contact for EKM1,EKL3  
**EKM1-FB** Alarm Auxiliary Contact for EKM1,EKL3



**Technical Data**

<b>Electrical Features</b>	Rated value	AC415/400V 50/60Hz 3A
		AC240/400V 50/60Hz 3A
		DC130V 1A
		DC48V 2A
		DC24V 6A
	Configurations	EKM1-OF 1N/O+1N/C
		EKM1-FB 2N/O+2N/C
		Rated impulse withstand voltage (1.2/50)U <sub>imp</sub>
	Rated short circuit making capacity	20I <sub>e</sub> , t=0.1s
	Dielectric test voltage at ind. Freq. for 1min	2kV
	Insulation voltage U <sub>i</sub>	500V
	Pollution degree	2
<b>Mechanical Features</b>	Electrical life	6,000 Cycles
	Mechanical life	10,000 Cycles
	Protection degree	IP20
	Ambient temperature (with daily average ≤35°C)	-5°C~+40°C
	Storage temperature	-25°C~+70°C
<b>Installation</b>	Terminal connection type	Cable
	Terminal size top/bottom for cable	2.5mm <sup>2</sup> 18-13AWG
	Tightening torque	0.8 Nm 7In-lbs

**Overall and Installation Dimension(mm)**

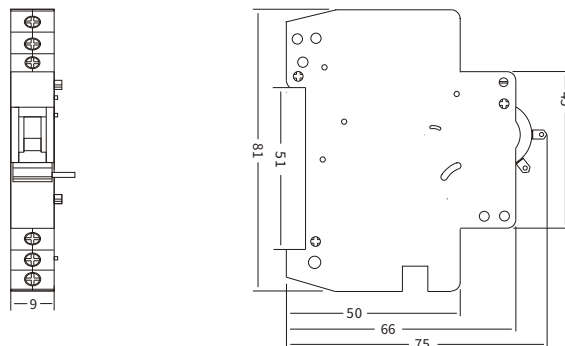

**EKM1-MX** Shunt Release  
**EKM1-MV+MN** Over/Under-voltage Tripper



**Technical Data**

<b>Electrical Features</b> <b>EKM1-MX</b>	Rated voltage US(V)	AC230/400 50/60Hz DC24 DC48 AC24 50/60Hz
	Rated impulse withstand voltage (1.2/50)U <sub>imp</sub>	4,000V
	Rated short circuit making capacity	20I <sub>e</sub> , t=0.1s
	Dielectric test voltage at ind. Freq. for 1min	2kV
	Insulation voltage U <sub>i</sub>	500V
	Pollution degree	2
<b>EKM1-MV+MN</b>	Rated voltage (U <sub>e</sub> )	AC230V
	Rated insulating voltage(U <sub>i</sub> )	500V
	Over-voltage tripping range	280V±5%
	Under-voltage tripping range	170V±5%
	Mounted on the right side of circuit breaker, actuate the combined device to trip in case of under-voltage or over-voltage, effectively prevent the device from closing operation under abnormal power voltage condition.	
<b>Mechanical Features</b>	Electrical life	4,000 Cycles
	Mechanical life	4,000 Cycles
	Protection degree	IP20
	Ambient temperature (with daily average ≤35°C)	-5°C~+40°C
	Storage temperature	-25°C~+70°C
<b>Installation</b>	Terminal connection type	Cable
	Terminal size top/bottom for cable	2.5mm <sup>2</sup> 18-13AWG
	Tightening torque	0.8 Nm 7In-lbs

**Overall and Installation Dimension(mm)**

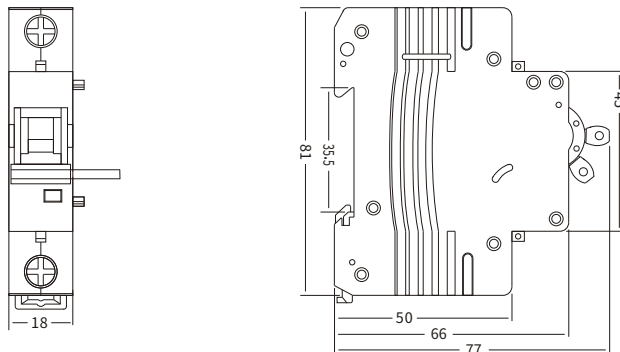



## Handle Lock for MCB

### Specification

Model No. EKLK18	It is used to lock Breaker handle on the OFF or ON position.	
Suitable for MCB,RCCB,RCBO		
Colour	Yellow	
Material	Nylon PA66 and Stainless	



## Plug Part for MCB

### Specification

It is used to seal the MCB screw hole for protecting and locking		
Colour	Light Grey	
Material	Nylon PA66	
Model No. EKM1PL		
Suitable for MCB Model EKM1-63,EKM1-63H,EKM1-63DC,RCBO Model EKL3-40		
Model No. EKM1PLS		
Suitable for MCB Model EKM1-63S		

# EKM2-63S 4.5KA/6KA MCB

Mini Circuit Breaker

**ETEK**<sup>®</sup>

Standard\_ IEC60898-1



## Technical Data

<b>Electrical Features</b>	Rated current $I_n$	1,2,3,4,5,6,8,10,13,16,20,25,32,40,50,63A
	Poles	1P, 1P+N, 2P, 3P, 3P+N,4P
	Rated voltage $U_e$	240/415V~
	Insulation voltage $U_i$	500V
	Rated frequency	50/60Hz
	Rated breaking capacity	1-40A 6,000A / 50-63A 4,500A
	Energy limiting class	3
	Rated impulse withstand voltage(1.5/50) $U_{imp}$	4,000V
	Dielectric test voltage at ind. Freq. for 1 min	2kV
	Pollution degree	2
Thermo-magnetic release characteristic	B,C,D	
<b>Mechanical Features</b>	Electrical life	4,000 Cycles
	Mechanical life	10,000 Cycles
	Contact position indicator	Yes
	Protection degree	IP20
	Reference temperature for setting of thermal element	30°C
	Ambient temperature (with daily average $\leq 35^\circ\text{C}$ )	-5°C~+40°C
Storage temperature	-25°C~+70°C	
<b>Installation</b>	Terminal connection type	Cable/Pin-type busbar
	Terminal size top/bottom for cable	25mm <sup>2</sup> 18-3AWG
	Terminal size top/bottom for busbar	25mm <sup>2</sup> 18-3AWG
	Tightening torque	2.5Nm 22In-lbs
	Mounting	On DIN rail EN60715(35mm) by means of fast clip device
	Connection	From top and bottom
<b>Combination with accessories</b>	Auxiliary contact	EKM1S-OF
	Alarm contact	EKM1S-FB
	Shunt release	EKM1S-MX
	Over/Under voltage release	EKM1S-MV+MN

# EKM2-63S 4.5KA/6KA MCB

Mini Circuit Breaker



Standard\_ IEC60898-1

## MCB Characteristics

### Characteristics Curves

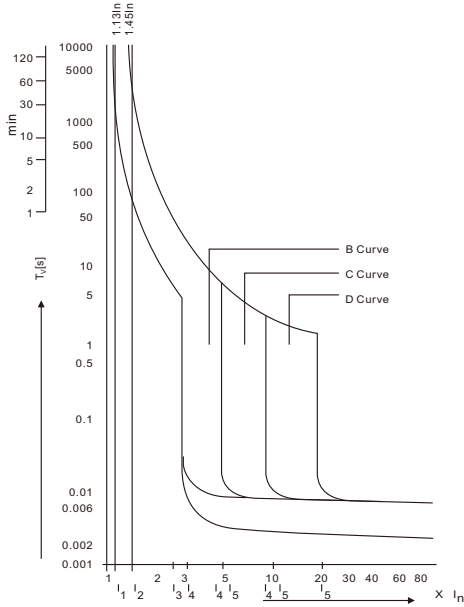

As per IEC60898	Thermal Tripping		Magnetic Tripping			
	No tripping current	Tripping current $I_2$	Time Limits t	Hold current $I_4$	Trip current $I_5$	Time Limits t
B Curve	$1.13 \times I_N$	$1.45 \times I_N$	$\geq 1h$	$3 \times I_N$	$5 \times I_N$	$\geq 0.1s$
			$< 1h$			$< 0.1s$
C Curve	$1.13 \times I_N$	$1.45 \times I_N$	$\geq 1h$	$5 \times I_N$	$10 \times I_N$	$\geq 0.1s$
			$< 1h$			$< 0.1s$
D Curve	$1.13 \times I_N$	$1.45 \times I_N$	$\geq 1h$	$10 \times I_N$	$20 \times I_N$	$\geq 0.1s$
			$< 1h$			$< 0.1s$

### Tripping characteristics

Based on the Tripping Characteristics, MCB are available in “B”, “C” and “D” curve to suit different types of applications.

“B” Curve for protection of electrical circuits with equipment that does not cause surge current (lighting and distribution circuits) Short circuit release is set to (3-5)In.

“C” Curve for protection of electrical circuits with equipment that cause surge current (inductive loads and motor circuits) Short circuit release is set to (5-10)In.

“D” Curve for protection of electrical circuits with cause high inrush current, typically 12-15 times the thermal rated current (transformes, x-ray machines etc,) Short circuit release is set to (10-20)In.

### Circuit Diagram

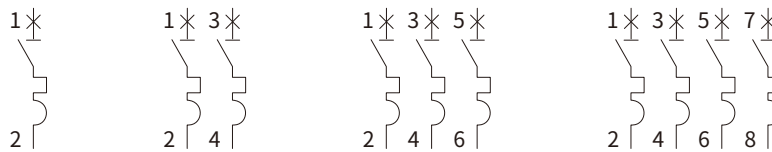

## Overall and Installation Dimension(mm)

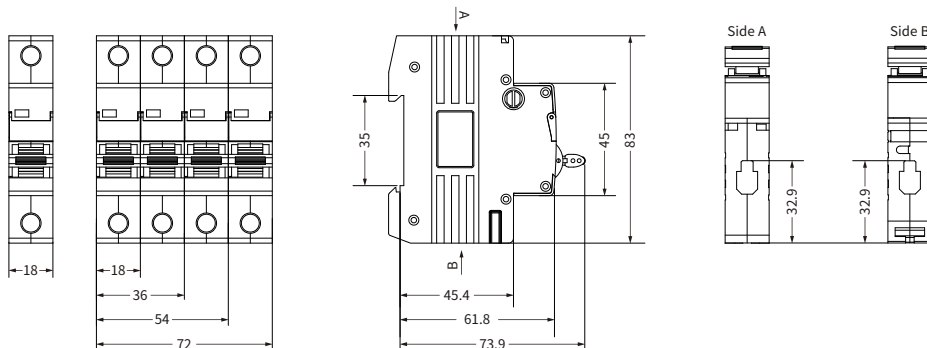

# EKM2-63 6KA MCB

Mini Circuit Breaker

**ETEK**<sup>®</sup>

Standard\_ IEC60898-1



## Technical Data

<b>Electrical Features</b>	Rated current $I_n$	1,2,3,4,5,6,8,10,13,16,20,25,32,40,50,63A
	Poles	1P, 1P+N, 2P, 3P, 3P+N,4P
	Rated voltage $U_e$	240/415V~
	Insulation voltage $U_i$	500V
	Rated frequency	50/60Hz
	Rated breaking capacity	6,000A
	Energy limiting class	3
	Rated impulse withstand voltage(1.5/50) $U_{imp}$	4,000V
	Dielectric test voltage at ind. Freq. for 1 min	2kV
	Pollution degree	2
Thermo-magnetic release characteristic	B,C,D	
<b>Mechanical Features</b>	Electrical life	8,000 Cycles
	Mechanical life	20,000 Cycles
	Contact position indicator	Yes
	Protection degree	IP20
	Reference temperature for setting of thermal element	30°C
	Ambient temperature (with daily average $\leq 35^\circ\text{C}$ )	-5°C~+40°C
	Storage temperature	-25°C~+70°C
<b>Installation</b>	Terminal connection type	Cable/Pin-type busbar/U-type busbar
	Terminal size top/bottom for cable	25mm <sup>2</sup> 18-3AWG
	Terminal size top/bottom for busbar	25mm <sup>2</sup> 18-3AWG
	Tightening torque	2.5Nm 22In-lbs
	Mounting	On DIN rail EN60715(35mm) by means of fast clip device
	Connection	From top and bottom
<b>Combination with accessories</b>	Auxiliary contact	EKM2-OF
	Alarm contact	EKM2-FB
	Shunt release	EKM2-MX
	Over/Under voltage release	EKM2-MV+MN

### MCB Characteristics

#### Characteristics Curves

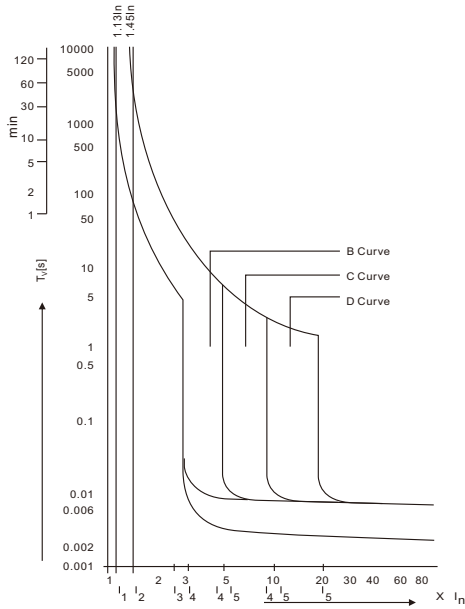

As per IEC60898	Thermal Tripping		Magnetic Tripping			
	No tripping current	Tripping current $I_2$	Time Limits t	Hold current $I_4$	Trip current $I_5$	Time Limits t
B Curve	$1.13 \times I_N$	$1.45 \times I_N$	$\geq 1h$	$3 \times I_N$	$5 \times I_N$	$\geq 0.1s$
			$< 1h$			$< 0.1s$
C Curve	$1.13 \times I_N$	$1.45 \times I_N$	$\geq 1h$	$5 \times I_N$	$10 \times I_N$	$\geq 0.1s$
			$< 1h$			$< 0.1s$
D Curve	$1.13 \times I_N$	$1.45 \times I_N$	$\geq 1h$	$10 \times I_N$	$20 \times I_N$	$\geq 0.1s$
			$< 1h$			$< 0.1s$

#### Tripping characteristics

Based on the Tripping Characteristics, MCB are available in “B”, “C” and “D” curve to suit different types of applications.

“B” Curve for protection of electrical circuits with equipment that does not cause surge current (lighting and distribution circuits) Short circuit release is set to (3-5)In.

“C” Curve for protection of electrical circuits with equipment that cause surge current (inductive loads and motor circuits) Short circuit release is set to (5-10)In.

“D” Curve for protection of electrical circuits with cause high inrush current, typically 12-15 times the thermal rated current (transformes, x-ray machines etc,) Short circuit release is set to (10-20)In.

#### Circuit Diagram

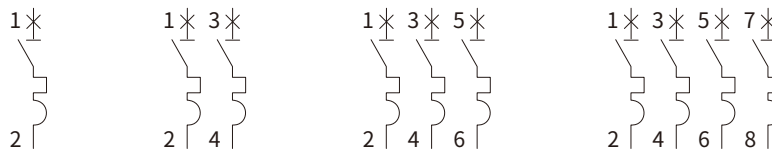

### Overall and Installation Dimension (mm)

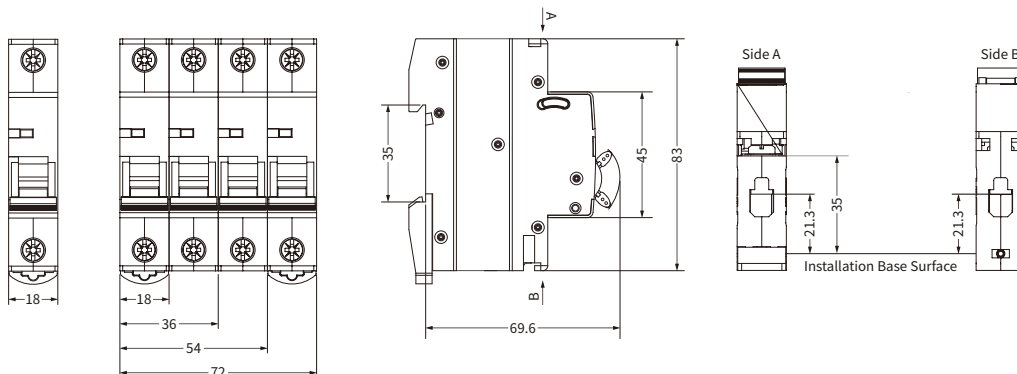

# EKM2-63H 10KA MCB

Mini Circuit Breaker

**ETEK**<sup>®</sup>

Standard\_ IEC60898-1



## Technical Data

<b>Electrical Features</b>	Rated current I <sub>n</sub>	1,2,3,4,5,6,8,10,13,16,20,25,32,40,50,63A
	Poles	1P, 1P+N, 2P, 3P, 3P+N,4P
	Rated voltage U <sub>e</sub>	240/415V~
	Insulation voltage U <sub>i</sub>	500V
	Rated frequency	50/60Hz
	Rated breaking capacity	10,000A
	Energy limiting class	3
	Rated impulse withstand voltage(1.5/50) U <sub>imp</sub>	4,000V
	Dielectric test voltage at ind. Freq. for 1 min	2kV
	Pollution degree	2
Thermo-magnetic release characteristic	B,C,D	
<b>Mechanical Features</b>	Electrical life	8,000 Cycles
	Mechanical life	20,000 Cycles
	Contact position indicator	Yes
	Protection degree	IP20
	Reference temperature for setting of thermal element	30°C
	Ambient temperature (with daily average ≤35°C)	-5°C~+40°C
	Storage temperature	-25°C~+70°C
<b>Installation</b>	Terminal connection type	Cable/Pin-type busbar/U-type busbar
	Terminal size top/bottom for cable	25mm <sup>2</sup> 18-3AWG
	Terminal size top/bottom for busbar	25mm <sup>2</sup> 18-3AWG
	Tightening torque	2.5Nm 22In-lbs
	Mounting	On DIN rail EN60715(35mm) by means of fast clip device
	Connection	From top and bottom
<b>Combination with accessories</b>	Auxiliary contact	EKM2-OF
	Alarm contact	EKM2-FB
	Shunt release	EKM2-MX
	Over/Under voltage release	EKM2-MV+MN





# EKM2-32N 6KA MCB

Mini Circuit Breaker

**ETEK**<sup>®</sup>

Standard\_ IEC60898-1



## Technical Data

<b>Electrical Features</b>	Rated current $I_n$	6,8,10,13,16,20,25,32A
	Poles	1P+N
	Rated voltage $U_e$	230/240V~
	Insulation voltage $U_i$	500V
	Rated frequency	50/60Hz
	Rated breaking capacity	6,000A
	Energy limiting class	3
	Rated impulse withstand voltage(1.5/50) $U_{imp}$	4,000V
	Dielectric test voltage at ind. Freq. for 1 min	2kV
	Pollution degree	2
Thermo-magnetic release characteristic	B,C	
<b>Mechanical Features</b>	Electrical life	4,000 Cycles
	Mechanical life	10,000 Cycles
	Contact position indicator	Yes
	Protection degree	IP20
	Reference temperature for setting of thermal element	30°C
	Ambient temperature (with daily average $\leq 35^\circ\text{C}$ )	-5°C~+40°C
	Storage temperature	-25°C~+70°C
<b>Installation</b>	Terminal connection type	Cable/Pin-type busbar
	Terminal size top/bottom for cable	16mm <sup>2</sup> 18-5AWG
	Terminal size top/bottom for busbar	16mm <sup>2</sup> 18-5AWG
	Tightening torque	1.5Nm 14In-lbs
	Mounting	On DIN rail EN60715(35mm) by means of fast clip device
	Connection	From top and bottom
<b>Combination with accessories</b>	Auxiliary contact	EKM2-OF
	Alarm contact	EKM2-FB
	Shunt release	EKM2-MX
	Over/Under voltage release	EKM2-MV+MN

### MCB Characteristics

#### Characteristics Curves

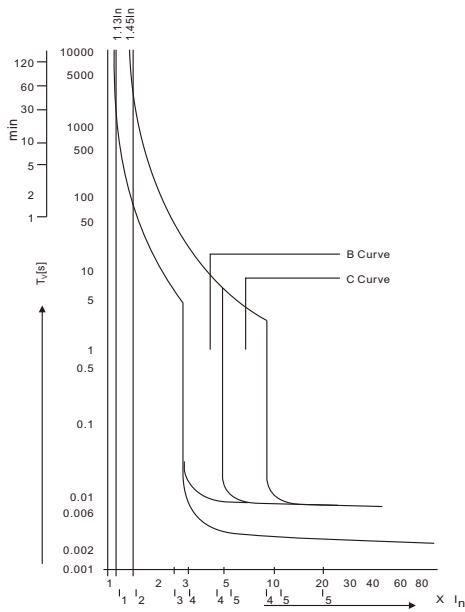

As per IEC60898	Thermal Tripping		Magnetic Tripping			
	No tripping current	Tripping current $I_2$	Time Limits t	Hold current $I_4$	Trip current $I_5$	Time Limits t
B Curve	$1.13 \times I_N$	$1.45 \times I_N$	$\geq 1h$ $< 1h$	$3 \times I_N$	$5 \times I_N$	$\geq 0.1s$ $< 0.1s$
C Curve	$1.13 \times I_N$	$1.45 \times I_N$	$\geq 1h$ $< 1h$	$5 \times I_N$	$10 \times I_N$	$\geq 0.1s$ $< 0.1s$

#### Tripping characteristics

Based on the Tripping Characteristics, MCB are available in “B”, “C” and “D” curve to suit different types of applications.

“B” Curve for protection of electrical circuits with equipment that does not cause surge current (lighting and distribution circuits) Short circuit release is set to (3-5)In.

“C” Curve for protection of electrical circuits with equipment that cause surge current (inductive loads and motor circuits) Short circuit release is set to (5-10)In.

#### Circuit Diagram



### Overall and Installation Dimension(mm)

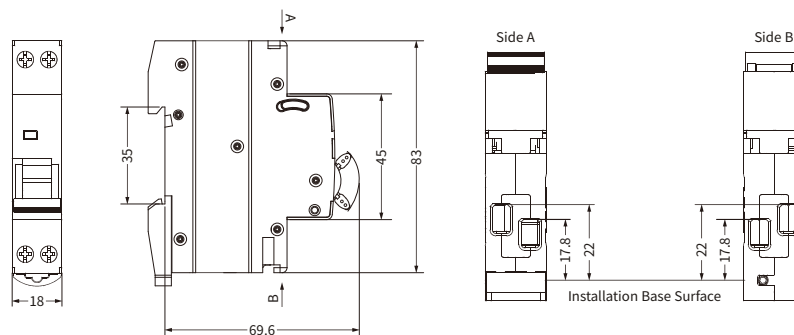

# EKM2-125H 10KA MCB

Mini Circuit Breaker

**ETEK®**

Standard\_ IEC60947-2



## Technical Data

<b>Electrical Features</b>	Rated current $I_n$	63,80,100,125A
	Poles	1P,1P+N,2P,3P,3P+N,4P
	Rated voltage $U_e$	240/415V~
	Insulation voltage $U_i$	500V
	Rated frequency	50/60Hz
	Rated breaking capacity	10,000A
	Energy limiting class	3
	Rated impulse withstand voltage(1.5/50) $U_{imp}$	4,000V
	Dielectric test voltage at ind. Freq. for 1 min	2kV
Pollution degree	2	
Thermo-magnetic release characteristic	8-12In	
<b>Mechanical Features</b>	Electrical life	2,000 Cycles
	Mechanical life	10,000 Cycles
	Contact position indicator	Yes
	Protection degree	IP20
	Reference temperature for setting of thermal element	30°C
	Ambient temperature (with daily average $\leq 35^\circ\text{C}$ )	-5°C~+40°C
	Storage temperature	-25°C~+70°C
<b>Installation</b>	Terminal connection type	Cable/Pin-type busbar
	Terminal size top/bottom for cable	50mm <sup>2</sup> 18-2AWG
	Terminal size top/bottom for busbar	50mm <sup>2</sup> 18-2AWG
	Tightening torque	3.5Nm 30In-lbs
	Mounting	On DIN rail EN60715(35mm) by means of fast clip device
	Connection	From top and bottom
<b>Combination with accessories</b>	Auxiliary contact	EKM2-OF
	Alarm contact	EKM2-FB
	Shunt release	EKM2-MX
	Over/Under voltage release	EKM2-MV+MN

# EKM2-125H 10KA MCB

Mini Circuit Breaker



Standard\_ IEC60947-2

## MCB Characteristics

Characteristics  
Curves

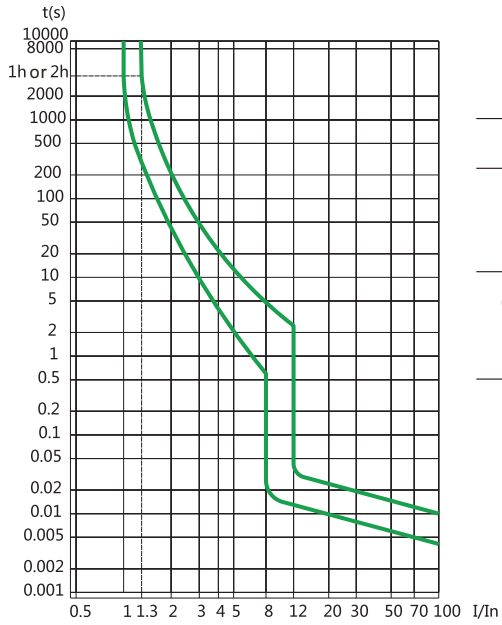

As per IEC60947	Thermal Tripping		Magnetic Tripping			
	No tripping current	Tripping current $I_2$	Time Limits t	Hold current $I_4$	Trip current $I_5$	Time Limits t
63-125A	$1.05 \times I_N$		$\geq 2h$ $< 1h$	$8 \times I_N$		$\geq 0.2s$ $< 0.2s$
		$1.30 \times I_N$			$12 \times I_N$	

Circuit  
Diagram

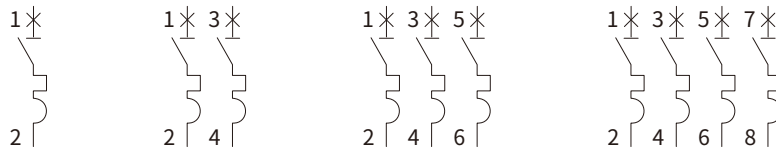

## Overall and Installation Dimension(mm)

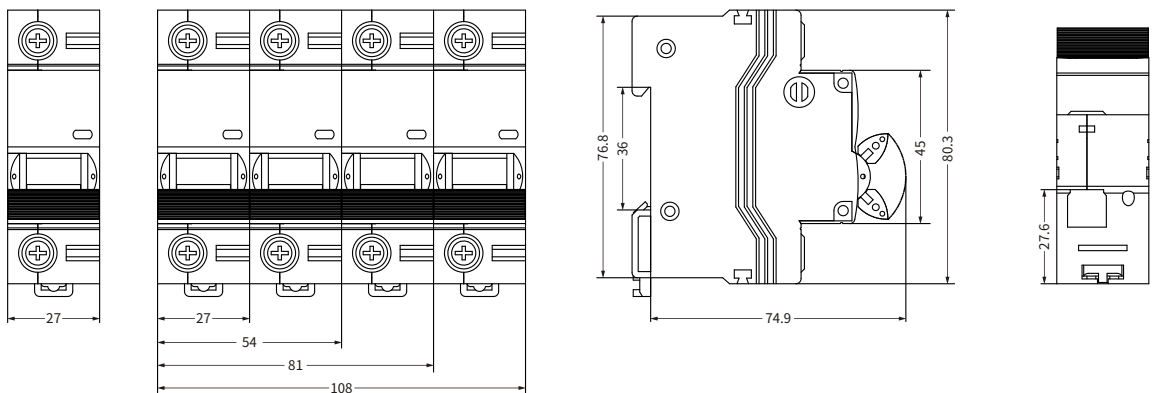

# EKL6-100 6KA RCCB EKL6-100H 10KA RCCB



Residual Current Circuit Breaker

Standard\_ IEC61008-1



## Technical Data

Electrical Features	Mode	Electromagnetic
	Type	AC,A,G,S
	Rated current $I_n$	25,40,63,80,100A
	Poles	2P(1P+N),4P(3P+N)
	Rated voltage $U_e$	2P 240V~
		4P 415V~
	Insulation voltage $U_i$	500V
	Rated frequency	50/60Hz
	Rated residual operation current( $I_{\Delta n}$ )	30,100,300mA
	Rated residual making and breaking capacity ( $I_{\Delta m}$ )	630
	Short-circuit current $I_{nc} = I_{\Delta c}$	6,000A/10,000A
	SCPD fuse	[6000] /  [10000]
	Break time under $I_{\Delta n}$	$\leq 0.1s$
	Rated impulse withstand voltage(1.5/50) $U_{imp}$	4000V
	Dielectric test voltage at ind.Freq. for 1min	2.5kV
	Electrical life	2,000 Cycles
Mechanical life	4,000 Cycles	

Installation	Contact position indicator	Yes
	Protection degree	IP20
	Ambient temperature(with daily average $\leq 35^\circ C$ )	$-5^\circ C \sim +40^\circ C$
	Storage temperature	$-25^\circ C \sim +70^\circ C$
	Terminal connection type	Cable/Pin-type busbar
	Terminal size top/bottom for cable	35mm <sup>2</sup> 18-2AWG
	Terminal size top/bottom for busbar	35mm <sup>2</sup> 18-2AWG
	Tightening torque	3.0Nm 22In-lbs
	Mounting	On DIN rail EN60715(35mm) by means of fast clip device
	Connection	From top and bottom

# EKL6-100 6KA RCCB EKL6-100H 10KA RCCB





Residual Current Circuit Breaker

Standard\_ IEC61008-1

Tripping  
Current  
Range

Type	Tripping current $I_{\Delta}/A$		
AC	$0.5I_{\Delta n} < I_{\Delta} < I_{\Delta n}$		
A	Lagging Angle	$I_{\Delta n} > 0.01A$	$I_{\Delta n} \leq 0.01A$
	0°	$0.35I_{\Delta n} \leq I_{\Delta} \leq 1.4I_{\Delta n}$	$0.35I_{\Delta n} \leq I_{\Delta} \leq 2I_{\Delta n}$
	90°	$0.25I_{\Delta n} \leq I_{\Delta} \leq 1.4I_{\Delta n}$	$0.25I_{\Delta n} \leq I_{\Delta} \leq 2I_{\Delta n}$
	135°	$0.11I_{\Delta n} \leq I_{\Delta} \leq 1.4I_{\Delta n}$	$0.11I_{\Delta n} \leq I_{\Delta} \leq 2I_{\Delta n}$

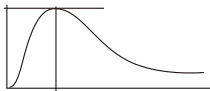
Alternative Current Sensitive	Pulsating direct current sensitive	Surge current proof
 <p>They react to AC current which, whether suddenly applied or slowly arising.</p>	 <p>They react to AC and pulsating DC fault current which reach 0 or almost 0 within one time period of the mains frequency.</p>	 <p>RCCB' s surge capacity. Not tripping at standardized 8/20 us surge-current waves acc.to VDE 0432 Part 2 with surge current values of up to 250A.</p>

Circuit  
Diagram

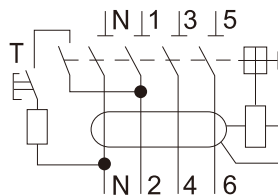
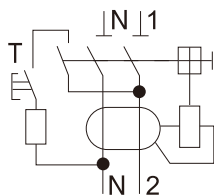

## Overall and Installation Dimension(mm)

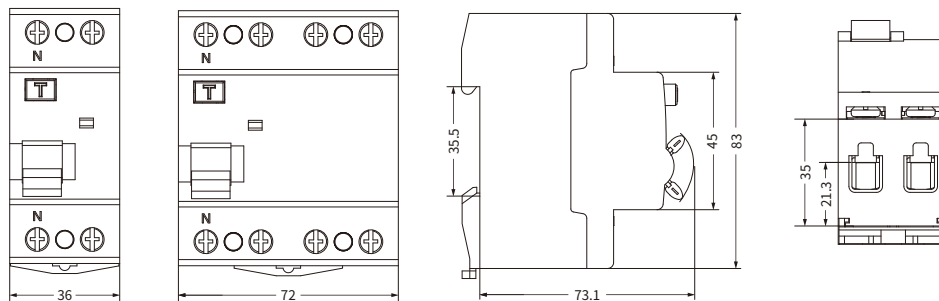

# EKL6-80B 10KA B Type RCCB

Residual Current Circuit Breaker

**ETEK**<sup>®</sup>

Standard\_ IEC61008-1  
IEC62423



## Technical Data

Electrical Features	Mode	Electromagnetic
	Type(wave form of the earth leakage sensed)	B
	Rated current $I_n$	25,40,63,80A
	Poles	2P,4P
	Rated voltage $U_e$	2P 240V~, 4P 415V~
	Insulation voltage $U_i$	500V
	Rated frequency	50/60Hz
	Rated residual operation current( $I_{\Delta n}$ )	30mA
	Rated residual making and breaking capacity ( $I_{\Delta m}$ )	500( $I_n=2540A$ ) 630( $I_n=63A$ )
	Short-circuit current $I_{nc} = I_{\Delta c}$	10,000A
	SCPD fuse	 10000
	Break time under $I_{\Delta n}$	$\leq 0.1s$
	Rated impulse withstand voltage(1.5/50) $U_{imp}$	4000V
	Dielectric test voltage at ind.Freq. for 1min	2.5kV
	Electrical life	2,000 Cycles
	Mechanical life	4,000 Cycles

Installation	Contact position indicator	Yes
	Protection degree	IP20
	Ambient temperature(with daily average $\leq 35^\circ C$ )	$-5^\circ C \sim +40^\circ C$
	Storage temperature	$-25^\circ C \sim +70^\circ C$
	Terminal connection type	Cable/Pin-type busbar/U-type busbar
	Terminal size top/bottom for cable	35mm <sup>2</sup> 18-3AWG
	Terminal size top/bottom for busbar	35mm <sup>2</sup> 18-3AWG
	Tightening torque	2.5Nm 22In-lbs
	Mounting	On DIN rail EN60715(35mm) by means of fast clip device
	Connection	From top and bottom



# EKL6-80B 10KA B Type RCCB

Residual Current Circuit Breaker



Standard\_ IEC61008-1  
IEC62423

Tripping Current Range	Lagging Angle	$I_{\Delta n} > 0.01A$	$I_{\Delta n} \leq 0.01A$
		0°	$0.35I_{\Delta n} \leq I_{\Delta} \leq 1.4I_{\Delta n}$
	90°	$0.25I_{\Delta n} \leq I_{\Delta} \leq 1.4I_{\Delta n}$	$0.25I_{\Delta n} \leq I_{\Delta} \leq 2I_{\Delta n}$
	135°	$0.11I_{\Delta n} \leq I_{\Delta} \leq 1.4I_{\Delta n}$	$0.11I_{\Delta n} \leq I_{\Delta} \leq 2I_{\Delta n}$

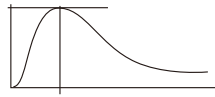
Detectable wave form	Pulsating direct current sensitive	Surge current proof
<p>B class</p> <p>Tripping is ensured for sinusoidal AC residual currents pulsed DC residual currents, alternating residual sinusoidal currents up to 1000Hz, pulsating direct residual currents and for smooth direct residual currents, whether applied suddenly or increasing slowly.</p>	 <p>They react to AC and pulsating DC fault current which reach 0 or almost 0 within one time period of the mains frequency.</p>	 <p>RCCB' s surge capacity. Not tripping at standardized 8/20 us surge-current waves acc.to VDE 0432 Part 2 with surge current values of up to 250A.</p>

## Circuit Diagram

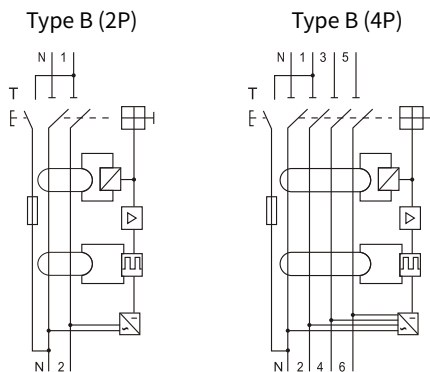

## Overall and Installation Dimension(mm)

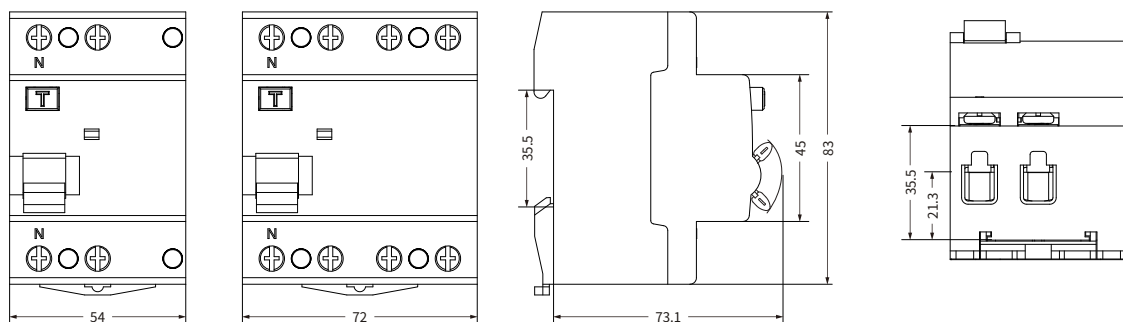

# EKL7-50 6KA RCBO

RCCB with Overcurrent Protection



Standard\_ IEC61009-1



## Technical Data

<b>Electrical Features</b>	Mode	Electronic
	Type	AC,A
	Rated current I <sub>n</sub>	6,8,10,13,16,20,25,32,40, 50A
	Poles	1P+N
	Rated voltage U <sub>e</sub>	240V~
	Insulation voltage U <sub>i</sub>	500V
	Rated frequency	50/60Hz
	Rated residual operating current(I $\Delta$ n)	10,30,100,300mA
	Break time under I $\Delta$ n	≤0.1s
	Rated breaking capacity	6,000A
	Energy limiting class	3
	Rated impulse withstand voltage(1.5/50) U <sub>imp</sub>	4,000V
	Dielectric test voltage at ind.Freq. for 1min	2kV
	Pollution degree	2
Thermo-magnetic release characteristic	B,C	
<b>Mechanical Features</b>	Electrical life	4,000 Cycles
	Mechanical life	10,000 Cycles
	Contact position indicator	Yes
	Protection degree	IP20
	Reference temperature for setting of thermal element	30°C
	Ambient temperature (with daily average ≤35°C)	-5°C~+40°C
	Storage temperature	-25°C~+70°C
<b>Installation</b>	Terminal connection type	Cable/Pin-type busbar/U-type busbar
	Terminal size top/bottom for cable	25mm <sup>2</sup> 18-3AWG
	Terminal size top/bottom for busbar	25mm <sup>2</sup> 18-3AWG
	Tightening torque	2.5Nm 22In-lbs
	Mounting	On DIN rail EN60715(35mm) by means of fast clip device
	Connection	From top
<b>Specialfunction can customized</b>	Over voltage protection	Yes
	Under voltage protection	Yes
	Over/Under voltage protection	Yes

# EKL7-50 6KA RCBO

RCCB with Overcurrent Protection



Standard\_ IEC61009-1

## Characteristics

Tripping Current Range	Type	Tripping current $I\Delta/A$	
	AC		$0.5I\Delta_n < I\Delta < I\Delta_n$
A	Lagging Angle	$I\Delta_n > 0.01A$	
	0°	$0.35I\Delta_n \leq I\Delta \leq 1.4I\Delta_n$	$I\Delta_n \leq 0.01A$ $0.35I\Delta_n \leq I\Delta \leq 2I\Delta_n$
	90°	$0.25I\Delta_n \leq I\Delta \leq 1.4I\Delta_n$	$0.25I\Delta_n \leq I\Delta \leq 2I\Delta_n$
	135°	$0.11I\Delta_n \leq I\Delta \leq 1.4I\Delta_n$	$0.11I\Delta_n \leq I\Delta \leq 2I\Delta_n$

## Characteristics Curves

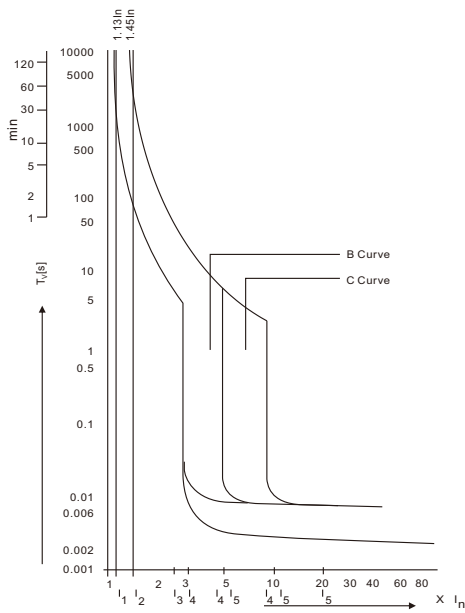

Thermal Tripping				Magnetic Tripping		
As per IEC60898	No tripping current	Tripping current $I_2$	Time Limits $t$	Hold current $I_4$	Trip current $I_5$	Time Limits $t$
B Curve	$1.13 \times I_N$		$\geq 1h$	$3 \times I_N$		$\geq 0.1s$
		$1.45 \times I_N$	$< 1h$			$5 \times I_N$
C Curve	$1.13 \times I_N$		$\geq 1h$	$5 \times I_N$		$\geq 0.1s$
		$1.45 \times I_N$	$< 1h$			$10 \times I_N$

## Circuit Diagram

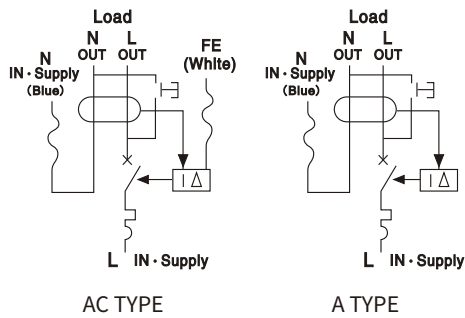

## Overall and Installation Dimension (mm)

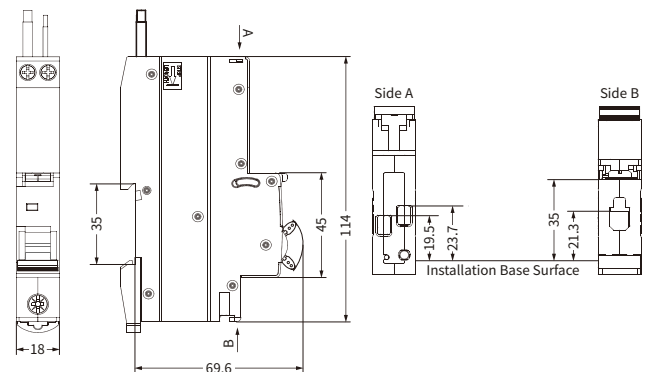

# EKL8-40M 6KA RCBO (Electromagnetic Type)

RCCB with Overcurrent Protection



Standard\_ IEC61009-1



## Technical Data

<b>Electrical Features</b>	Mode	Electromagnetic
	Type	AC,A
	Rated current I <sub>n</sub>	6,8,10,13,16,20,25,32,40A
	Poles	1P+N
	Rated voltage U <sub>e</sub>	230/240V~
	Insulation voltage U <sub>i</sub>	500V
	Rated frequency	50/60Hz
	Rated residual operating current(I <sub>Δn</sub> )	30,100,300mA
	Break time under I <sub>Δn</sub>	≤0.1s
	Rated breaking capacity	6,000A
	Energy limiting class	3
	Rated impulse withstand voltage(1.5/50) U <sub>imp</sub>	4,000V
	Dielectric test voltage at ind.Freq. for 1min	2kV
	Pollution degree	2
Thermo-magnetic release characteristic	B,C	
<b>Mechanical Features</b>	Electrical life	4,000 Cycles
	Mechanical life	10,000 Cycles
	Contact position indicator	Yes
	Protection degree	IP20
	Reference temperature for setting of thermal element	30°C
	Ambient temperature (with daily average ≤35°C)	-5°C~+40°C
	Storage temperature	-25°C~+70°C
<b>Installation</b>	Terminal connection type	Cable/Pin-type busbar/U-type busbar
	Terminal size top/bottom for cable	25mm <sup>2</sup> 18-3AWG
	Terminal size top/bottom for busbar	25mm <sup>2</sup> 18-3AWG
	Tightening torque	2.5Nm 22In-lbs
	Mounting	On DIN rail EN60715(35mm) by means of fast clip device
	Connection	From top and bottom
<b>Combination with accessories</b>	Auxiliary contact	EKM2-OF
	Alarm contact	EKM2-FB
	Shunt release	EKM2-MX

# EKL8-40M 6KA RCBO (Electromagnetic Type)

RCCB with Overcurrent Protection

Standard\_ IEC61009-1

## Characteristics

Tripping Current Range	Type	Tripping current $I\Delta/A$		
	AC		$0.5I\Delta n < I\Delta < I\Delta n$	
A	Lagging Angle	$I\Delta n > 0.01A$		$I\Delta n \leq 0.01A$
		0°	$0.35I\Delta n \leq I\Delta \leq 1.4I\Delta n$	$0.35I\Delta n \leq I\Delta \leq 2I\Delta n$
		90°	$0.25I\Delta n \leq I\Delta \leq 1.4I\Delta n$	$0.25I\Delta n \leq I\Delta \leq 2I\Delta n$
		135°	$0.11I\Delta n \leq I\Delta \leq 1.4I\Delta n$	$0.11I\Delta n \leq I\Delta \leq 2I\Delta n$

## Characteristics Curves

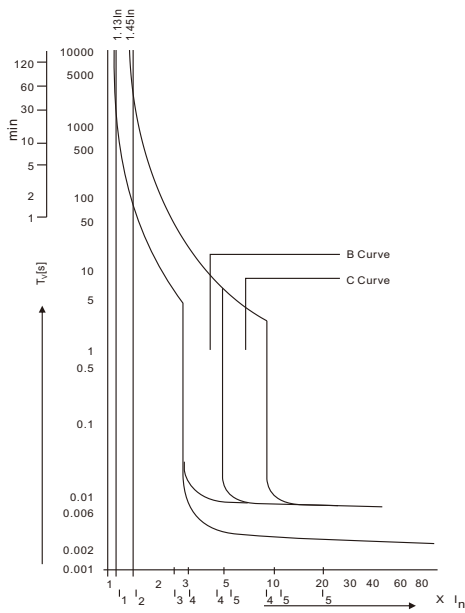

As per IEC60898	Thermal Tripping		Magnetic Tripping			
	No tripping current	Tripping current $I_2$	Time Limits $t$	Hold current $I_4$	Trip current $I_5$	Time Limits $t$
B Curve	$1.13 \times I_N$		$\geq 1h$	$3 \times I_N$		$\geq 0.1s$
		$1.45 \times I_N$	$< 1h$		$5 \times I_N$	$< 0.1s$
C Curve	$1.13 \times I_N$		$\geq 1h$	$5 \times I_N$		$\geq 0.1s$
		$1.45 \times I_N$	$< 1h$		$10 \times I_N$	$< 0.1s$

## Circuit Diagram

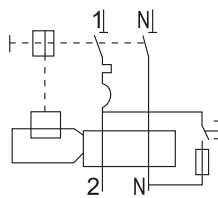

## Overall and Installation Dimension(mm)

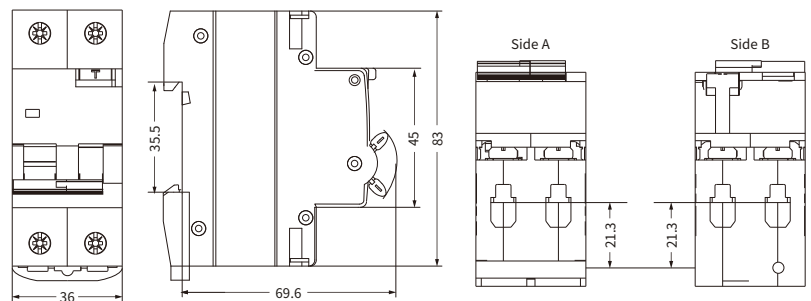

# EKL9-40 6KA RCBO

RCCB with Overcurrent Protection

**ETEK**<sup>®</sup>

Standard\_ IEC61009-1



## Technical Data

<b>Electrical Features</b>	Mode	Electronic
	Type	AC,A
	Rated current I <sub>n</sub>	6,8,10,13,16,20,25,32,40A
	Poles	1P+N
	Rated voltage U <sub>e</sub>	240V~
	Insulation voltage U <sub>i</sub>	500V
	Rated frequency	50/60Hz
	Rated residual operating current(I <sub>Δn</sub> )	10,30,100,300mA
	Break time under I <sub>Δn</sub>	≤0.1s
	Rated breaking capacity	6,000A
	Energy limiting class	3
	Rated impulse withstand voltage(1.5/50) U <sub>imp</sub>	4,000V
	Dielectric test voltage at ind.Freq. for 1min	2kV
	Pollution degree	2
Thermo-magnetic release characteristic	B,C	
<b>Mechanical Features</b>	Electrical life	4,000 Cycles
	Mechanical life	10,000 Cycles
	Contact position indicator	Yes
	Protection degree	IP20
	Reference temperature for setting of thermal element	30°C
	Ambient temperature (with daily average ≤35°C)	-5°C~+40°C
	Storage temperature	-25°C~+70°C
<b>Installation</b>	Terminal connection type	Cable/Pin-type busbar
	Terminal size top/bottom for cable	16mm <sup>2</sup> 18-5AWG
	Terminal size top/bottom for busbar	16mm <sup>2</sup> 18-5AWG
	Tightening torque	2.5Nm 22In-lbs
	Mounting	On DIN rail EN60715(35mm) by means of fast clip device
	Connection	From top and bottom
<b>Combination with accessories</b>	Auxiliary contact	EKM2-OF
	Alarm contact	EKM2-FB
	Shunt release	EKM2-MX
<b>Combination with accessories</b>	Over voltage protection	Yes
	Under voltage protection	Yes
	Over/Under voltage protection	Yes

# EKL9-40 6KA RCBO

RCCB with Overcurrent Protection



Standard\_ IEC61009-1

## Characteristics

Tripping Current Range	Type	Tripping current $I_{\Delta}/A$		
	AC		$0.5I_{\Delta n} < I_{\Delta} < I_{\Delta n}$	
A	Lagging Angle	$I_{\Delta n} > 0.01A$		$I_{\Delta n} \leq 0.01A$
	0°	$0.35I_{\Delta n} \leq I_{\Delta} \leq 1.4I_{\Delta n}$		$0.35I_{\Delta n} \leq I_{\Delta} \leq 2I_{\Delta n}$
	90°	$0.25I_{\Delta n} \leq I_{\Delta} \leq 1.4I_{\Delta n}$		$0.25I_{\Delta n} \leq I_{\Delta} \leq 2I_{\Delta n}$
	135°	$0.11I_{\Delta n} \leq I_{\Delta} \leq 1.4I_{\Delta n}$		$0.11I_{\Delta n} \leq I_{\Delta} \leq 2I_{\Delta n}$

## Characteristics Curves

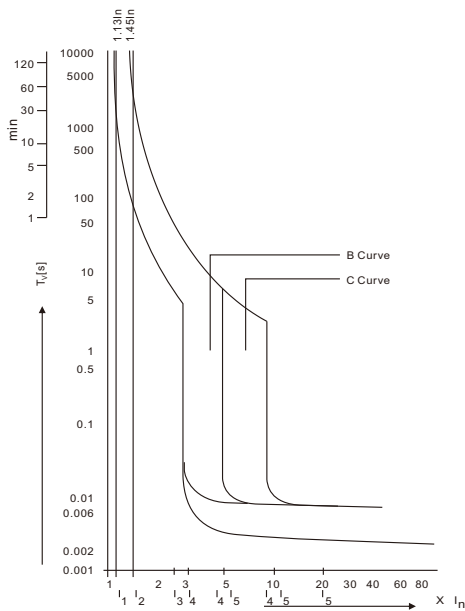

As per IEC60898	Thermal Tripping		Magnetic Tripping			
	No tripping current	Tripping current $I_2$	Time Limits t	Hold current $I_4$	Trip current $I_5$	Time Limits t
B Curve	$1.13 \times I_N$	$1.45 \times I_N$	$\geq 1h$	$3 \times I_N$	$5 \times I_N$	$\geq 0.1s$
			$< 1h$			$< 0.1s$
C Curve	$1.13 \times I_N$	$1.45 \times I_N$	$\geq 1h$	$5 \times I_N$	$10 \times I_N$	$\geq 0.1s$
			$< 1h$			$< 0.1s$

## Circuit Diagram

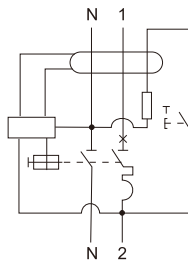

## Overall and Installation Dimension (mm)

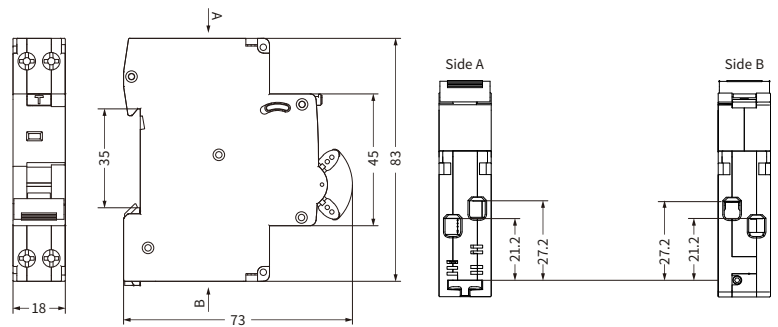



### Protection

- ① Arc Fault Protection
- ② Overload Protection
- ③ Short-Circuit Protection
- ④ Earth-Leakage Protection

### Technical Data

CONTENTS	TECHNICAL PARAMETERS
Rated voltage (Ue)	AC230V
Rated insulationRated frequency voltage (Ui)	50HZ±2%
Rated insulation voltage (Ui)	400V
Rated impulse withstand voltage(Uimp)	4KV
Rated current (In)	6A, 10A, 16A, 20A, 25A, 32A, 40A
Number of poles	1P+N(N pole disconnectable)
Magnetic tripping type	B-type, C-type
Rated service short circuit capacity (Ics)	6KA
Rated short circuit capacity (Icn)	6KA
Insulation material class	IIIa
Grid distance (mm)	40mm
Rated sensitivity	30mA type A, AC
Wide	36mm

### Overall and Installation Dimension(mm)

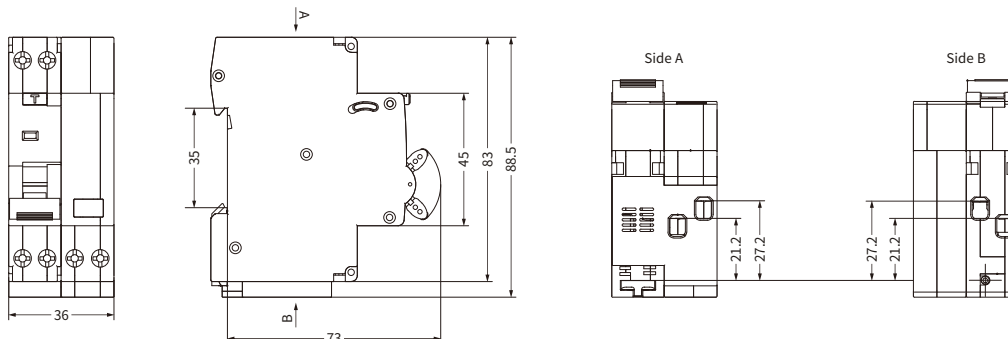





### Technical Data

<b>Electrical Features</b>	Rated current In	32,40,50,63,80,100,125A
	Poles	1P,2P,3P,4P
	Rated voltage Ue	240/415V~
	Insulation voltage Ui	500V
	Rated frequency	50/60Hz
	Rated short-time withstand current Icw	12Ie,1s
	Rated making and breaking capacity	3Ie,1.05Ue,cos φ=0.65
	Rated short circuit making capacity	20Ie,t=0.1s
	Rated impulse withstand voltage(1.5/50) Uimp	4,000V
	Dielectric test voltage at ind.Freq. for 1min	2.5kV
Utilization category	AC-22A	
<b>Mechanical Features</b>	Electrical life	4,000 Cycles
	Mechanical life	10,000 Cycles
	Contact position indicator	Yes
	Protection degree	IP20
<b>Installation</b>	Terminal connection type	Cable/Pin-type busbar/U-type busbar
	Terminal size top/bottom for cable	50mm <sup>2</sup> 18-2AWG
	Terminal size top/bottom for busbar	50mm <sup>2</sup> 18-2AWG
	Tightening torque	3.5Nm 30In-lbs
	Mounting	On DIN rail EN60715(35mm) by means of fast clip device
	Connection	From top and bottom

### Overall and Installation Dimension(mm)

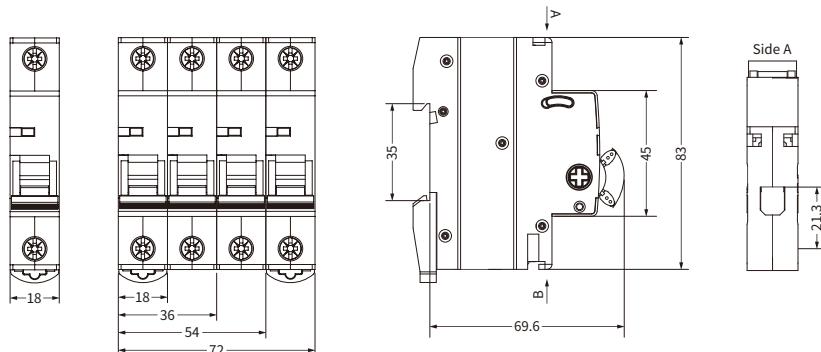

# DZ47-63S 4.5KA MCB (Economic Type)

Mini Circuit Breaker

Standard\_ IEC60898-1



## Technical Data

<b>Electrical Features</b>	Rated current $I_n$	1,2,3,4,5,6,8,10,13,16,20,25,32,40,50,63A
	Poles	1P,1P+N,2P,3P,3P+N,4P
	Rated voltage $U_e$	240/415V~
	Insulation voltage $U_i$	500V
	Rated frequency	50/60Hz
	Rated breaking capacity	4,500A
	Energy limiting class	3
	Rated impulse withstand voltage(1.5/50) $U_{imp}$	4,000V
	Dielectric test voltage at ind. Freq. for 1 min	2kV
	Pollution degree	2
Thermo-magnetic release characteristic	B,C,D	
<b>Mechanical Features</b>	Electrical life	4,000 Cycles
	Mechanical life	10,000 Cycles
	Contact position indicator	Yes
	Protection degree	IP20
	Reference temperature for setting of thermal element	30°C
	Ambient temperature (with daily average $\leq 35^\circ\text{C}$ )	-5°C~+40°C
	Storage temperature	-25°C~+70°C
<b>Installation</b>	Terminal connection type	Cable/Pin-type busbar
	Terminal size top/bottom for cable	25mm <sup>2</sup> 18-3AWG
	Terminal size top/bottom for busbar	25mm <sup>2</sup> 18-3AWG
	Tightening torque	2.5Nm 22In-lbs
	Mounting	On DIN rail EN60715(35mm) by means of fast clip device
	Connection	From top and bottom
<b>Combination with accessories</b>	Auxiliary contact	DZ47-OF
	Alarm contact	DZ47-FB
	Shunt release	DZ47-MX
	Over/Under voltage release	DZ47-MV+MN

# DZ47-63S 4.5KA MCB (Economic Type)

Mini Circuit Breaker



Standard\_ IEC60898-1

## MCB Characteristics

### Characteristics Curves

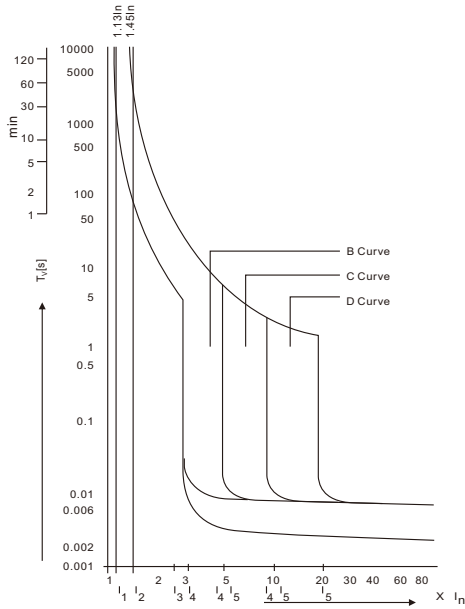

As per IEC60898	Thermal Tripping		Magnetic Tripping			
	No tripping current	Tripping current $I_2$	Time Limits t	Hold current $I_4$	Trip current $I_5$	Time Limits t
B Curve	$1.13 \times I_N$	$1.45 \times I_N$	$\geq 1h$	$3 \times I_N$	$5 \times I_N$	$\geq 0.1s$
			$< 1h$			$< 0.1s$
C Curve	$1.13 \times I_N$	$1.45 \times I_N$	$\geq 1h$	$5 \times I_N$	$10 \times I_N$	$\geq 0.1s$
			$< 1h$			$< 0.1s$
D Curve	$1.13 \times I_N$	$1.45 \times I_N$	$\geq 1h$	$10 \times I_N$	$20 \times I_N$	$\geq 0.1s$
			$< 1h$			$< 0.1s$

### Tripping characteristics

Based on the Tripping Characteristics, MCB are available in “B”, “C” and “D” curve to suit different types of applications.

“B” Curve for protection of electrical circuits with equipment that does not cause surge current (lighting and distribution circuits) Short circuit release is set to (3-5)  $I_N$ .

“C” Curve for protection of electrical circuits with equipment that cause surge current (inductive loads and motor circuits) Short circuit release is set to (5-10)  $I_N$ .

“D” Curve for protection of electrical circuits with cause high inrush current, typically 12-15 times the thermal rated current (transformes, x-ray machines etc,) Short circuit release is set to (10-20)  $I_N$ .

### Circuit Diagram

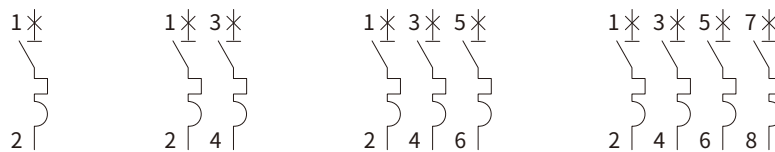

## Overall and Installation Dimension(mm)

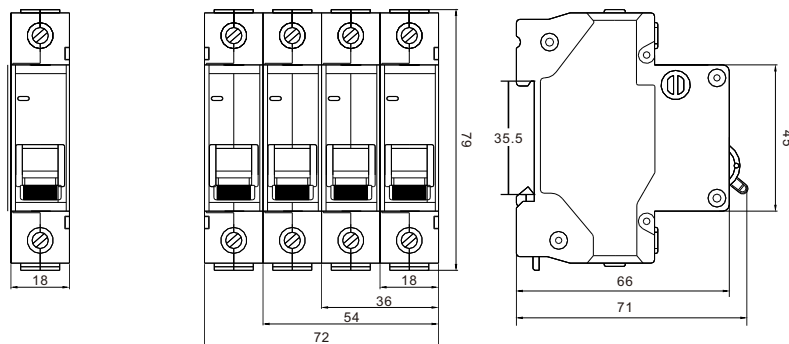

# EKM1-125S 6KA MCB

Mini Circuit Breaker

**ETEK**<sup>®</sup>

Standard\_ IEC60898-1



## Technical Data

<b>Electrical Features</b>	Rated current $I_n$	63,80,100,125A
	Poles	1P, 1P+N, 2P, 3P, 3P+N,4P
	Rated voltage $U_e$	240/415V~
	Insulation voltage $U_i$	500V
	Rated frequency	50/60Hz
	Rated breaking capacity	6,000A
	Energy limiting class	3
	Rated impulse withstand voltage(1.5/50) $U_{imp}$	4,000V
	Dielectric test voltage at ind. Freq. for 1 min	2kV
	Pollution degree	2
Thermo-magnetic release characteristic	B,C,D	
<b>Mechanical Features</b>	Electrical life	4,000 Cycles
	Mechanical life	10,000 Cycles
	Contact position indicator	Yes
	Protection degree	IP20
	Reference temperature for setting of thermal element	30°C
	Ambient temperature (with daily average $\leq 35^\circ\text{C}$ )	-5°C~+40°C
	Storage temperature	-25°C~+70°C
<b>Installation</b>	Terminal connection type	Cable/Pin-type busbar/U-type busbar
	Terminal size top/bottom for cable	50mm <sup>2</sup> 18-2AWG
	Terminal size top/bottom for busbar	50mm <sup>2</sup> 18-2AWG
	Tightening torque	3.5Nm 30In-lbs
	Mounting	On DIN rail EN60715(35mm) by means of fast clip device
	Connection	From top and bottom

### MCB Characteristics

#### Characteristics Curves

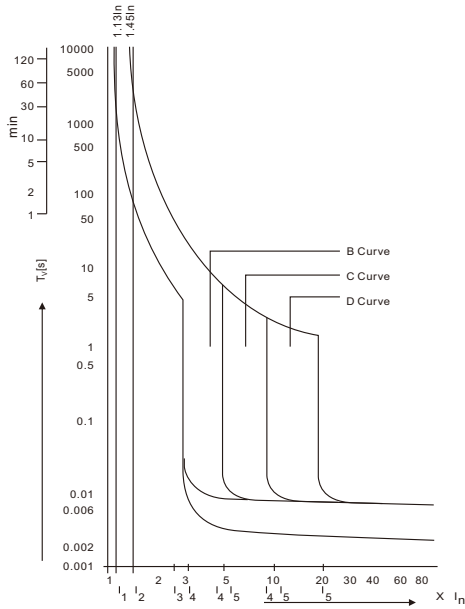

As per IEC60898	Thermal Tripping		Magnetic Tripping			
	No tripping current	Tripping current $I_2$	Time Limits t	Hold current $I_4$	Trip current $I_5$	Time Limits t
B Curve	$1.13 \times I_N$	$1.45 \times I_N$	$\geq 1h$	$3 \times I_N$	$5 \times I_N$	$\geq 0.1s$
			$< 1h$			$< 0.1s$
C Curve	$1.13 \times I_N$	$1.45 \times I_N$	$\geq 1h$	$5 \times I_N$	$10 \times I_N$	$\geq 0.1s$
			$< 1h$			$< 0.1s$
D Curve	$1.13 \times I_N$	$1.45 \times I_N$	$\geq 1h$	$10 \times I_N$	$20 \times I_N$	$\geq 0.1s$
			$< 1h$			$< 0.1s$

#### Tripping characteristics

Based on the Tripping Characteristics, MCB are available in “B”, “C” and “D” curve to suit different types of applications.

“B” Curve for protection of electrical circuits with equipment that does not cause surge current (lighting and distribution circuits) Short circuit release is set to (3-5)  $I_N$ .

“C” Curve for protection of electrical circuits with equipment that cause surge current (inductive loads and motor circuits) Short circuit release is set to (5-10)  $I_N$ .

“D” Curve for protection of electrical circuits with cause high inrush current, typically 12-15 times the thermal rated current (transformes, x-ray machines etc,) Short circuit release is set to (10-20)  $I_N$ .

#### Circuit Diagram

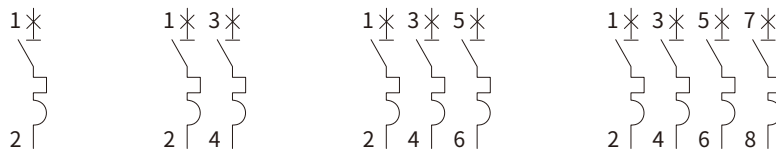

### Overall and Installation Dimension (mm)

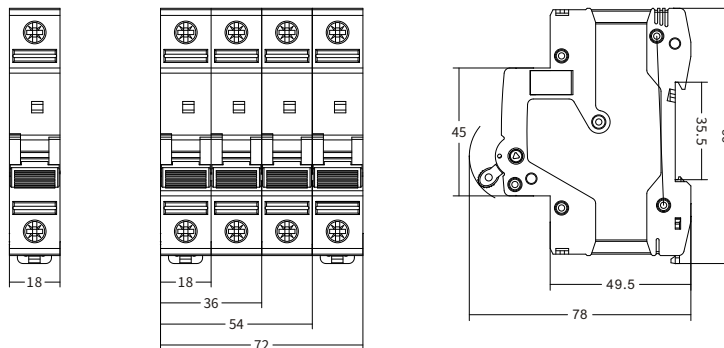

# EKM2-125 6KA MCB (Economic Type)

Mini Circuit Breaker

**ETEK**<sup>®</sup>

Standard\_ IEC60947-2



## Technical Data

<b>Electrical Features</b>	Rated current $I_n$	63,80,100,125A
	Poles	1P,1P+N,2P,3P,3P+N,4P
	Rated voltage $U_e$	240/415V~
	Insulation voltage $U_i$	500V
	Rated frequency	50/60Hz
	Rated breaking capacity	10,000A
	Energy limiting class	3
	Rated impulse withstand voltage(1.5/50) $U_{imp}$	4,000V
	Dielectric test voltage at ind. Freq. for 1 min	2kV
Pollution degree	2	
Thermo-magnetic release characteristic	8-12In	
<b>Mechanical Features</b>	Electrical life	4,000 Cycles
	Mechanical life	10,000 Cycles
	Contact position indicator	Yes
	Protection degree	IP20
	Reference temperature for setting of thermal element	30°C
	Ambient temperature (with daily average $\leq 35^\circ\text{C}$ )	-5°C~+40°C
	Storage temperature	-25°C~+70°C
<b>Installation</b>	Terminal connection type	Cable/Pin-type busbar
	Terminal size top/bottom for cable	50mm <sup>2</sup> 18-2AWG
	Terminal size top/bottom for busbar	50mm <sup>2</sup> 18-2AWG
	Tightening torque	3.5Nm 30In-lbs
	Mounting	On DIN rail EN60715(35mm) by means of fast clip device
	Connection	From top and bottom
<b>Combination with accessories</b>	Auxiliary contact	EKM2-OF
	Alarm contact	EKM2-FB
	Shunt release	EKM2-MX
	Over/Under voltage release	EKM2-MV+MN

# EKM2-125 6KA MCB (Economic Type)

Mini Circuit Breaker



Standard\_ IEC60947-2

## MCB Characteristics

Characteristics  
Curves

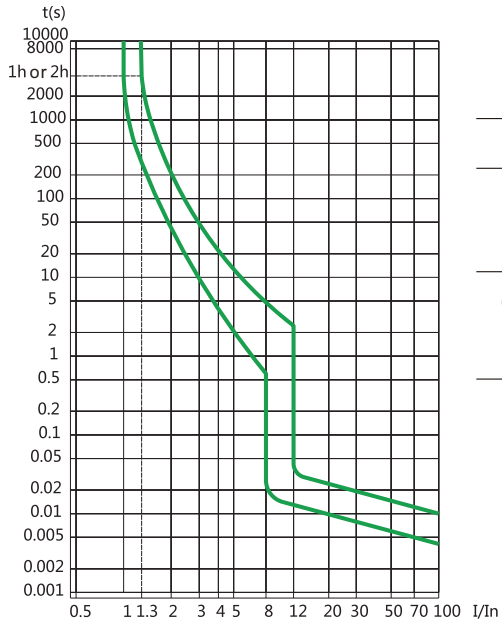

As per IEC60947	Thermal Tripping		Magnetic Tripping			
	No tripping current	Tripping current $I_2$	Time Limits t	Hold current $I_4$	Trip current $I_5$	Time Limits t
63-125A	$1.05 \times I_N$		$\geq 2h$ $< 1h$	$8 \times I_N$		$\geq 0.2s$ $< 0.2s$
		$1.30 \times I_N$			$12 \times I_N$	

Circuit  
Diagram

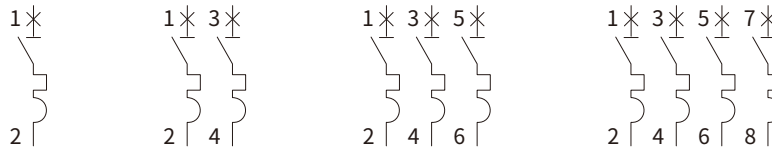

## Overall and Installation Dimension(mm)

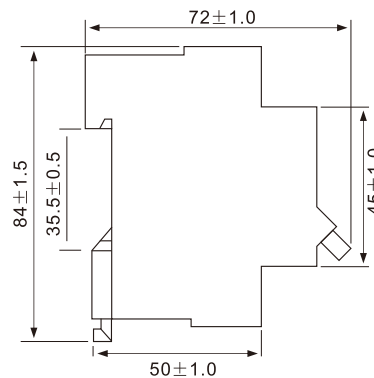
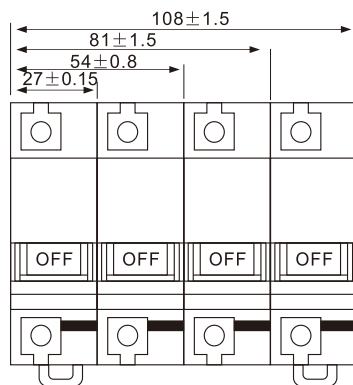

### Automatic Type



### Manual Type



### Technical Data

#### Electrical Features

Voltage rating(Ue)	1P, 2P	250V AC
	3P, 4P	400V AC
Frequency	50/60Hz	
Endurance(O-C)		
Electrical life	100,000	
Maximum number of switching operation a day	100	
Additional characteristics		
Insulation vwlage(Ui)	500V AC	
Pollution degree	2	
Rated impulse withstand voltage(Uimp)	2.5kV(4kV@ 12/24/48VAC)	
Degree of protection	IP20	
(IEC 60529)	IP40	
Operating temperature	-5°C~+60°C(1)	
Storage temperature	-40°C~+70°C	
Tropicalization(IEC 60068-1)	Treatment 2(relative humidity 95% at 55°C)	
ELSV compliance(Extra Low Safety Voltage)for 12/24/48VAC versions		
The product control conforms to the SELV(safety extra low voltage)requirements		

(1)In the case of contactor mounting in a enclosure for which the interior temperature is in range between 50°Cand 60°C, it is necessary to use a spacer, between each contactor



### Connection

Type	Rating	Length tripping	Circuit	Tightening torque	Copper cables	
					Rigid	Flexible or ferrule
EKMF	PZ1:4MM	16-100A	Control	0.8N.m		
		16~25A			1.5~2.5mm <sup>2</sup> 2×1.5mm <sup>2</sup>	1.5~2.5mm <sup>2</sup> 2×2.5mm <sup>2</sup>
	PZ2:6MM	40A-63A	Power	3.5N.m	1.5~6mm <sup>2</sup>	1~4mm <sup>2</sup>
		100A			6~25mm <sup>2</sup> 6×3.5mm <sup>2</sup>	6~16mm <sup>2</sup> 6~35mm <sup>2</sup>

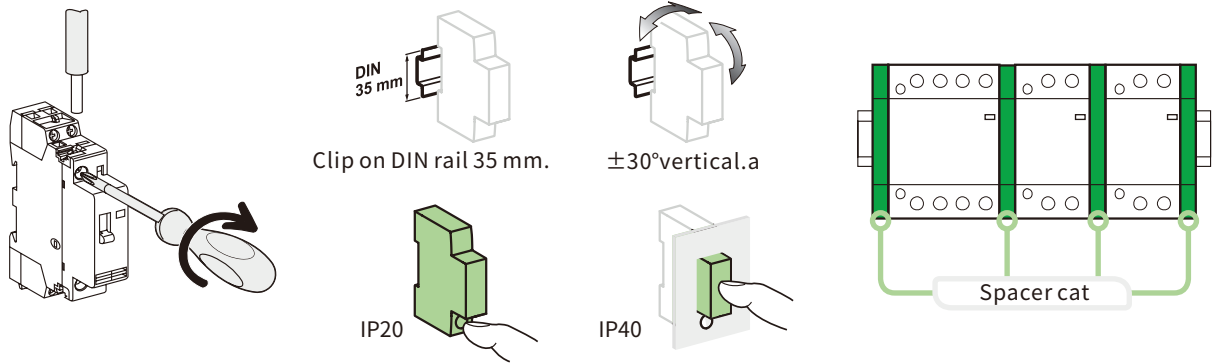

### Consumption

EKMF Contactors -50Hz	Rating(In)		Control voltage(VAC)(50/60 Hz)	Consumption		Max. power
	AC-7a	AC-7b		Holding	Inrush	
2P	16A	6A	220...240	2.7VA	9.2VA	1.2W
	20A	7A	220...240	2.7VA	9.2VA	1.2W
	25A	9A	220...240	3.8VA	15VA	1.2W
	40A	18A	220...240	4.6VA	34VA	1.6W
	63A	25A	220...240	4.6VA	34VA	1.6W
	100A	-	220...240	6.5VA	53VA	2.1W
4P	16A	6A	220...240	4.6VA	34VA	1.6W
	25A	9A	220...240	4.6VA	34VA	1.6W
	32A	12A	220...240	6.5VA	53VA	2.1W
	40A	18A	220...240	6.5VA	53VA	2.1W
	63A	25A	220...240	6.5VA	53VA	2.1W
	100A	-	220...240	13VA	106VA	4.2W

EKMF  
Manual  
Control  
Contactor  
-50Hz

	Rating(In)		Control voltage(VAC)(50/60 Hz)	Consumption		Max. power
	AC-7a	AC-7b		Holding	Inrush	
2P	25A	9A	230...240	2.7VA	9.2VA	1.2W
	40A	18A	220...240	4.6VA	34VA	1.6W
	63A	25A	220...240	4.6VA	34VA	1.6W
4P	25A	9A	220...240	4.6VA	34VA	1.6W
	40A	18A	220...240	6.5VA	53VA	2.1W
	63A	25A	220...240	6.5VA	53VA	2.1W

Circuit  
Diagram

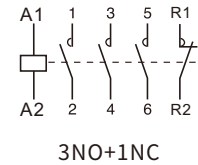
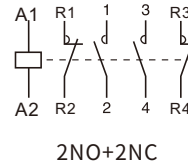
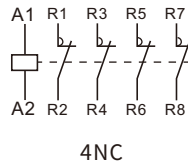
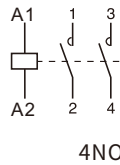
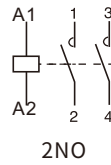
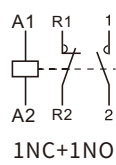
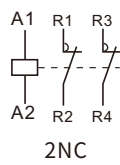

### Overall and Installation Dimension(mm)

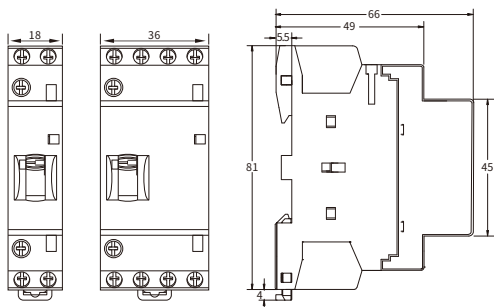

EKMF-16/20/25A

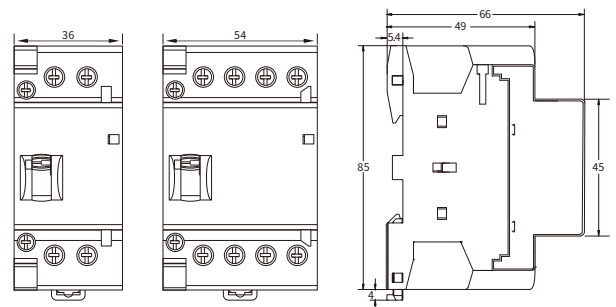

EKMF-32/40/63A

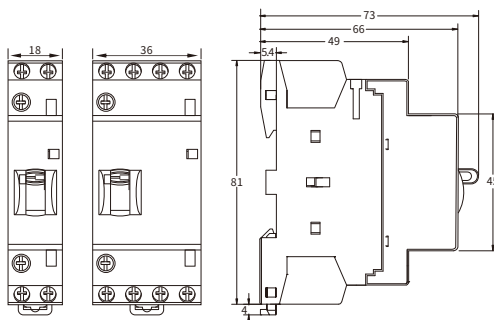

EKMF manual control contactor 16/25A

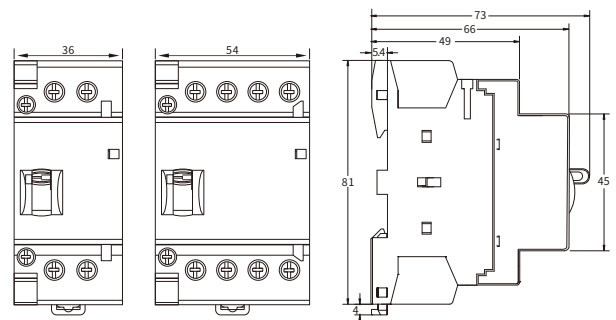

EKMF manual control contactor 40/63A



### Application

The type 2 surge protective device are applicable to discharge overvoltage caused by switch-type (8/20μs wave-form) over currents. The type 2 arresters must be installed into sub-distribution boards (at condominium into distribution boards of flats) after main distribution boards containing type 1 arresters. For proper operation at least 10- 15 m cable or wire must be placed between type 1 and type 2 arresters. Otherwise a decoupling coil has to be installed between the two devices. These protectors are modular types with changeable insert; the auxiliary contact is built-in into the housing of the device.

### Overall and Installation Dimension(mm)

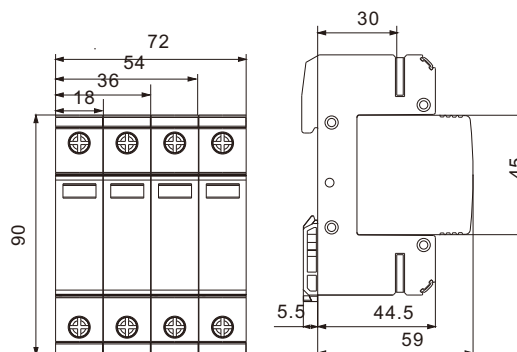

### Technical Data

Model	EKU4-20		EKU4-40		EKU4-B+C		EKU4-60		EKU4-80		EKU4-100		
Type	D		C		B+C		B		B		B		
Rated Voltage(Un)	275V	385V	275V	385V	275V	385V	275V	385V	275V	385V	275V	385V	
Maximum Continuous Operation Voltage(Uc)	275V	385V	275V	385V	275V	385V	275V	385V	275V	385V	275V	385V	
Voltage Protection Level (Up)	1.2KV	1.5KV	1.3KV	1.6KV	1.5KV	2.0KV	1.4KV	2.0KV	1.6KV	2.2KV	2.0KV	2.5KV	
Nominal Discharge Current In (8/20μs)	10KA	10KA	20KA	20KA	30KA	30KA	30KA	30KA	40KA	40KA	60KA	60KA	
Maximum Discharge Current I <sub>max</sub> (8/20μs)	20KA	20KA	40KA	40KA	50KA	50KA	60KA	60KA	80KA	80KA	100KA	100KA	
Maximum Discharge Current I <sub>max</sub> (10/350μs)					7KA	7KA							
Reaction Time	<25ns		<25ns		<25ns		<25ns		<25ns		<25ns		
Test Level	T2		T2		T1+T2		T2		T2		T2		
Width/Pole	18mm		18mm		18mm		18mm		18mm		18mm		
Color Mark	Black		Yellow		Blue		Red		Red		Red		
Shell Material	PBT		PBT		PBT		PBT		PBT		PBT		
Ambient Temperature	-40°C~80°C		-40°C~80°C		-40°C~80°C		-40°C~80°C		-40°C~80°C		-40°C~80°C		
Fuse or Circuit Breaker Matched	20A		25A		32A		32A		32A		40A		
Terminal Specification	Line	2.5~35mm <sup>2</sup>		2.5~35mm <sup>2</sup>		2.5~35mm <sup>2</sup>		2.5~35mm <sup>2</sup>		2.5~35mm <sup>2</sup>		2.5~35mm <sup>2</sup>	
	PE	4.0~35mm <sup>2</sup>		4.0~35mm <sup>2</sup>		4.0~35mm <sup>2</sup>		4.0~35mm <sup>2</sup>		4.0~35mm <sup>2</sup>		4.0~35mm <sup>2</sup>	
	Signal	1.5mm <sup>2</sup>		1.5mm <sup>2</sup>		1.5mm <sup>2</sup>		1.5mm <sup>2</sup>		1.5mm <sup>2</sup>		1.5mm <sup>2</sup>	
No.of Pole	1P, 2P, 3P, 4P, 1P+N, 2P+N, 3P+N												
Protection Degree	IP20												
Mounting	DIN rail 35mm												
Network System	TN, TT, IT												
Signal Terminal	Available												



### Application

The function of lightning and surge protection systems is to protect the devices, functional isolations and overvoltage-sensitive consumer equipments of energy distribution systems against all lightning and overvoltage damages. whole building; the outdoor lightning protection system is generally not sufficient to eliminate such malfunctions. At most of types, the defected protection device can be made operative again by changing the damaged insert; these variants are also equipped with both optical operation signal and auxiliary status contact.

### Overall and Installation Dimension(mm)

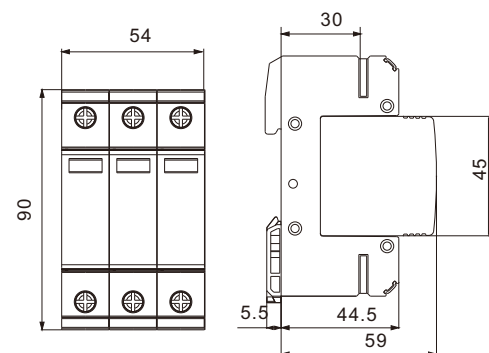

### Technical Data

Model and Specification	EKU4-40Z/500	EKU4-40Z/800	EKU4-40Z/1000	
Rated Voltage(VDC)	500V	800V	1,000V	
Continuous Operation Voltage(VDC)	550V	850V	1,100V	
Voltage Protection Level of Up	2.5	3	3.6	
Nominal Discharge Current In (8/20μs)	20KA	20KA	20KA	
Maximum Discharge Current I <sub>max</sub> (8/20μs)	40KA	40KA	40KA	
Reaction Time	<25ns	<25ns	<25ns	
Width/Pole	18mm	18mm	18mm	
Shell Material	PBT	PBT	PBT	
Ambient Temperature	-40°C-80°C	-40°C-80°C	-40°C-80°C	
Fuse or Circuit Breaker Matched	25A	25A	25A	
Terminal Specification	Line	2.5~35mm <sup>2</sup>	2.5~35mm <sup>2</sup>	2.5~35mm <sup>2</sup>
	PE	2.5~35mm <sup>2</sup>	2.5~35mm <sup>2</sup>	2.5~35mm <sup>2</sup>
	Signal	1.5mm <sup>2</sup>	1.5mm <sup>2</sup>	1.5mm <sup>2</sup>
No.of Pole	V+/PE/V-	V+/PE/V-	V+/PE/V-	
Protection Degree	IP20	IP20	IP20	
Mounting	DIN rail 35mm	DIN rail 35mm	DIN rail 35mm	
Network System	PV	PV	PV	
Signal Terminal	Available	Available	Available	

## Modular Voltage Meter

Standard\_ IEC60051-1



EKMV3



EKMV1

### Technical Data

<b>Electrical Features</b>	Type	EKMV1: Single phase 1 LED digital display EKMV3: Three phase 3 LED digital display
	Terminal for wiring	Single phase L+N Three phase 3L+3N
	Digital colour	Red, Green
	Measurement voltage range	AC 80V~500V
	Rated frequency	50/60Hz
	Working current	≤20mA
	Measuring accuracy	1.0
	Measuring rate	>200MS/time
	Protection degree	IP20
	Electrical Life	≥15000 hours
<b>Working Conditions</b>	Ambient temperature(with daily average≤35°C)	-5°C~+40°C
	Storage temperature	-25°C~+70°C
	Air relative humidity	10-80%(no condensation)
	Working pressure	80~160Kpa
	Sunniness	No sunniness
<b>Installation</b>	Terminal for wiring	1.5mm <sup>2</sup>
	Mounting	On DIN rail EN60715(35mm) by means of fast clip device

### Overall and Installation Dimension(mm)

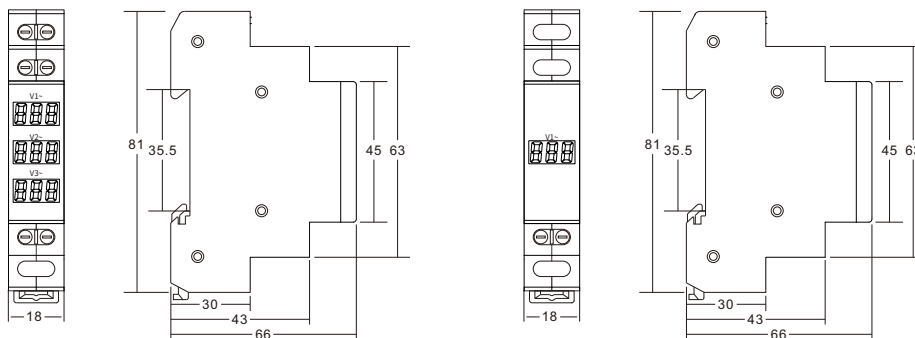

			
<p>Voltage+Amper Meter EKMVA-M2</p>	<p>Voltage+Amper Meter with C.T EKMVACT-M2</p>	<p>Amper Meter EKMA-M2</p>	<p>Amper Meter with C.T EKMVACT-M2</p>
<p>Modulars: 2(W=36mm) Measuring Range: 80-300V,0-999A Signal Input: AC 80-300V,5A Accuracy Class: <math>\pm(1\%FS+1digit)</math> Auxiliary Power: No</p>	<p>Modulars: 2(W=36mm) Measuring Range: 80-300V,0-100A Signal Input: AC 80-300V,0-100A Accuracy Class: <math>\pm(1\%FS+1digit)</math> Auxiliary Power: No</p>	<p>Modulars: 2(W=36mm) Measuring Range: 0-999A Signal Input: AC 5A Accuracy Class: <math>\pm(1\%FS+1digit)</math> Auxiliary Power: AC 80-300V</p>	<p>Modulars: 2(W=36mm) Measuring Range: 0-100A Signal Input: AC 0-100A Accuracy Class: <math>\pm(1\%FS+1digit)</math> Auxiliary Power: AC 80-300V</p>
			
<p>Voltage Meter EKMV-M2</p>	<p>Amper Meter EKMA-M3</p>	<p>Voltage Meter EKMV-M3</p>	<p>Hz Meter EKMHZ-M3</p>
<p>Modulars: 2(W=36mm) Measuring Range: 80-300V Signal Input: AC 80-300V,5A Accuracy Class: <math>\pm(1\%FS+1digit)</math> Auxiliary Power: No</p>	<p>Modulars: 3(W=54mm) Measuring Range: 0-9999A Signal Input: AC 5A Accuracy Class: <math>\pm(0.5\%FS+1digit)</math> Auxiliary Power: AC220V,50/60Hz</p>	<p>Modulars: 3(W=54mm) Measuring Range: 0-600V Signal Input: AC 0-600V Accuracy Class: <math>\pm(0.5\%FS+1digit)</math> Auxiliary Power: AC220V,50/60Hz</p>	<p>Modulars: 3(W=54mm) Measuring Range: 30-99A Signal Input: AC 30-500V Accuracy Class: <math>\pm(0.5\%FS+1digit)</math> Auxiliary Power: AC220V,50/60Hz</p>

Overall and Mounting Dimension(mm)

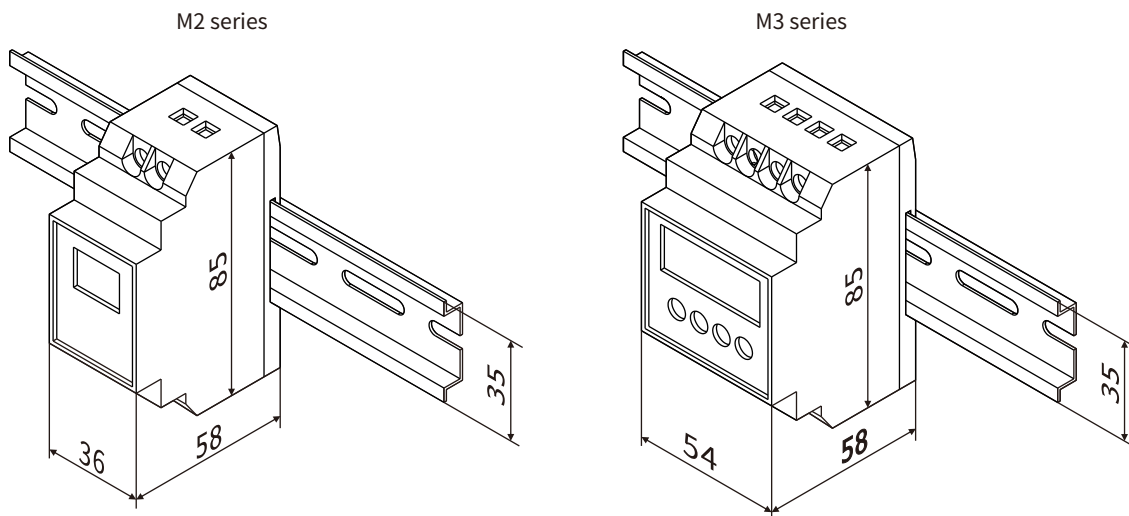



### Technical Data

**Application** Applicable to circuit with rated voltage 230V~and rated frequency 50/60Hz,used to power electric bell of extra low voltage.

<b>Construction and Feature</b>	Safe electrical separation between primary and secondary circuit
	Provides extra low voltage up to 24V
	Low temperature rising
	High output accuracy
Extra overload capacity up to 25% within 24 hours	

<b>Electrical Features</b>	Rated input voltage	230V AC
	Rated output voltage	8, 12, 16, 24V
	Rated frequency	50/60Hz
	Rated power output	8VA
	Consumption	0.9W
	Service period	Continuous operating
	Pollution class	2
	Connection terminals	Pillar terminal with clamp
	Connection capacity	Rigid conductor 10mm <sup>2</sup>
	Installation	On symmetrical DIN rail 35mm Panel mounting
Terminal Connection Height	H=15.5mm	

### Overall and Installation Dimension(mm)

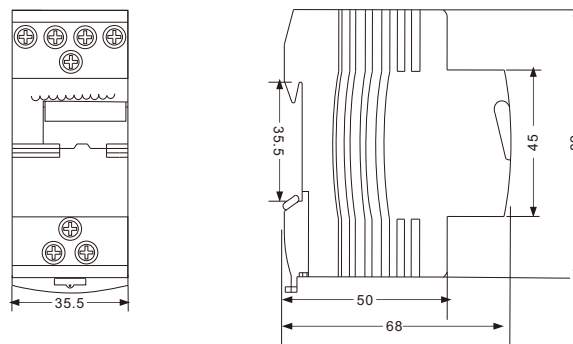



**Technical Data**

**Application** The electric bell is suitable for audible signaling for intermittent use only in domestic and commercial installations.

**Construction and Feature** Elegant appearance, compact size and easy installation  
 Low consumption  
 Product with rated current up to 24V AC to be powered by bell transformer EKEB.

<b>Electrical Features</b>	Rated voltage	8,12,24,230V AC
	Rated frequency	50/60Hz
	Service mode	Intermittent
	Connection terminal	Pillar terminal with clamp
	Connection capacity	Rigid conductor 10mm <sup>2</sup>
	Installation	On symmetrical DIN rail 35mm Panel mounting
	Terminal Connection Height	H=17mm

**Overall and Installation Dimension(mm)**

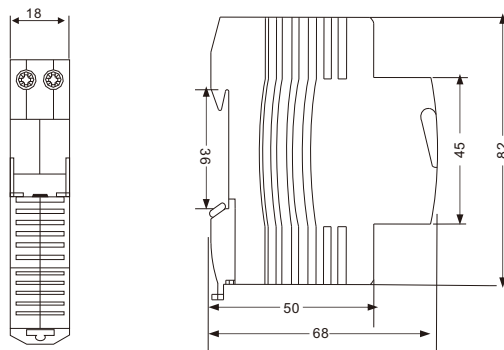



# EKSL1, EKSL3

Modular Signal Lamp

Standard\_ IEC60947-5-1



## Technical Data

**Application** The Modular Signal Lamp is applicable to circuit with rated voltage 230V~and frequency 50/60Hz for visual indication and signaling.

**Construction and Feature**  
 Low service duration, minimum power consumption  
 Compact design in modular size  
 Easy installation

<b>Technical Data</b>	Rated voltage	230V AC, 100V AC, 48V AC/DC, 24V AC/DC
	Rated frequency	50/60Hz
	Colour	EKSL1 Red, green, yellow EKSL3 Red/Green/Yellow, Red/Green/Blue
	Connection terminal	Pillar terminal with clamp
	Connection capacity	Rigid conductor 1.5mm <sup>2</sup>
	Installation	On symmetrical DIN rail 35mm
		Panel mounting
<b>EKSL1 EKSL3 signal lamp</b>	Max power	0.6W
	Illumination	LED
	Service duration	30,000 hours

## Circuit Diagram



## Overall and Installation Dimension(mm)

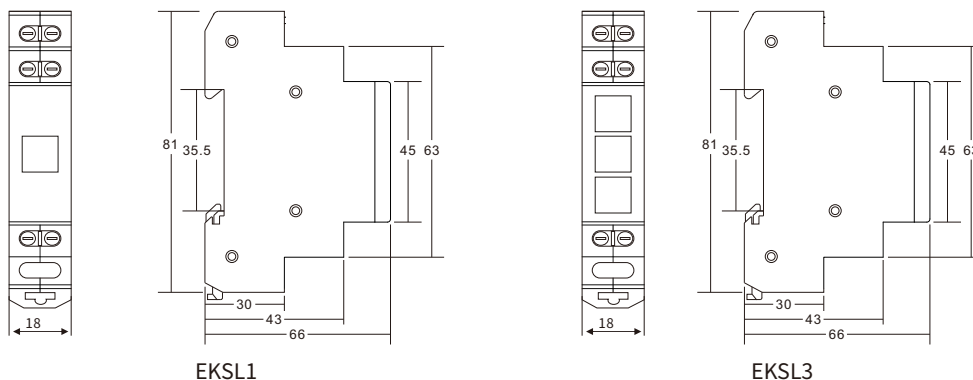



### Application

The Changeover Switch can switch on, Load and break the circuit under normal conditions, using as Switch Disconnectors.

<b>Technical Data</b>	Rated Voltage	240/415V~
	Rated Current	16,25,32,40A
	Rated Frequency	50/60Hz
	Number of Poles	1,2,3,4P
	Contact form	1-0-2
<b>Electrical Features</b>	Electrical Life	1500 Cycles
	Mechanical Life	8500 Cycles
	Protection degree	IP20
	Ambient Temperature	-5°C...40°C
<b>Electrical Features</b>	Terminal/Cable size	16mm <sup>2</sup>
	Mounting	On DIN rail EN60715(35mm) by means of fast clip device.

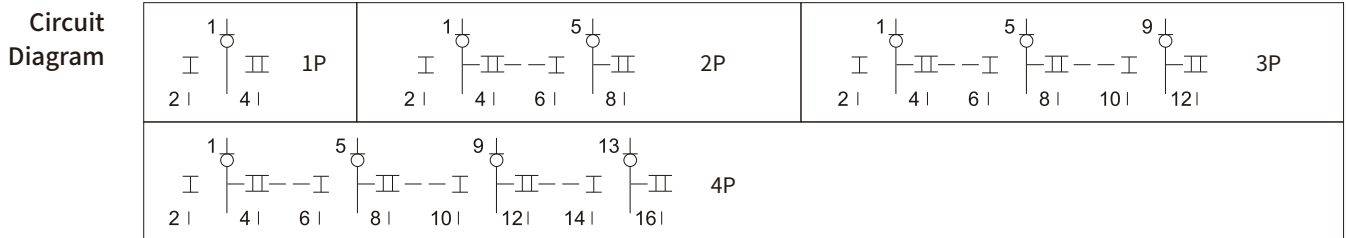

### Overall and Installation Dimension(mm)

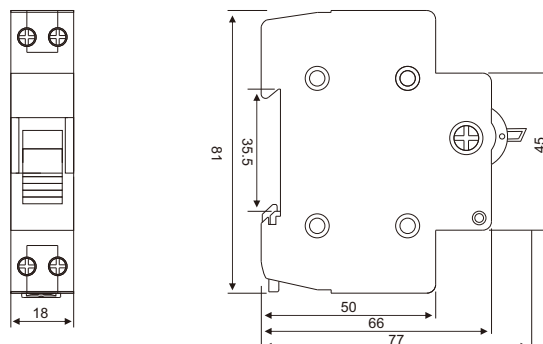

# EKP20 EKP7 EKP20B

Modular Socket

**ETAK**<sup>®</sup>

Standard\_ IEC60884



EKP20



EKP7



EKP20B

## Technical Data

EKP20, EKP20B and EKP7 Modular Socket can be used together with our modular products for connection of mobile devices, tools or electric and electronic non-Modular equipments directly inside civil and industrial switchboards.

Application	Model	Rated current(A)	Standard	Width(mm)	Connection capacity
	EKP20	16A	Germany	44.5	≤4mm <sup>2</sup>
	EKP7	16A	France	44.5	≤4mm <sup>2</sup>
	EKP20B	13A	UK	44.5	≤4mm <sup>2</sup>

Electrical Features	Value
Main voltage	230/400V, 50Hz/60Hz
Electric life	5,000 times
Rated insulation voltage Ui	500V
Rated impulse withstand voltage Uimp	5,000V
Dielectric test voltage at ind. Freq. For 1 min.	2.8kV
Mounting category	II, III
Pollution degree	2
Protection class	IP20
Standard mounting	35mm DIN rail
Ambient temperature	-5°C to +40°C
Storage temperature	-25°C to +70°C

## Overall and Installation Dimension(mm)

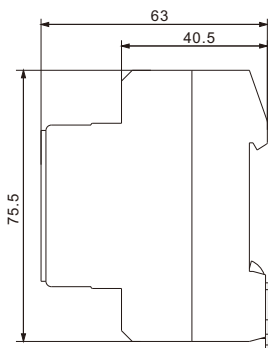

EKP20

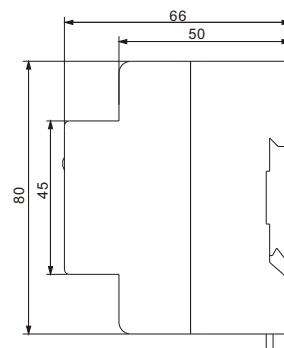
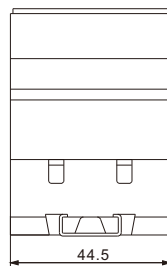

EKP7

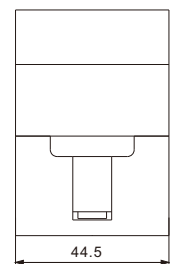



EKF1-32 3P



EKF1-32N 1P



EKF1-63 4P



EKF1-125 2P



EKF1-32L 4P



EKF1-63L 1P



EKF1-63L 3P



EKF1-125L 4P

## Technical Data

Rated current In		32A,63A,125A
Model No.	General type	EKF1-32,EKF1-63,EKF1-125
	With Indicator type	EKF1-32L,EKF1-63L,EKF1-125L
Poles		1P,2P,3P,4P,1P+N,3P+N
Utilization category		AC-22A
Rated voltage Ue		240/415V~
Insulation voltage Ui		500V
Rated frequency		50/60Hz
Rated impulse withstand voltage(1.5/50) Uimp		4,000V
Electrical life		1,500Cycles
Mechanical life		8,500Cycles
Operating frequency		120/h
Protection degree		IP20
Tightening torque	EKF1-32	1.5Nm 14In-lbs
	EKF1-63	2.5Nm 22In-lbs
	EKF1-125	3.5Nm 30In-lbs
Terminal size for cable	EKF1-32	16mm <sup>2</sup> 18-5AWG
	EKF1-63	25mm <sup>2</sup> 18-3AWG
	EKF1-125	50mm <sup>2</sup> 18-2AWG
Ambient temperature(with daily average≤35°C)		-5°C~+40°C
Storage temperature		-25°C~+70°C
Mounting		On DIN rail EN60715(35mm) by means of fast clip device

### Specifications

Model No.	Poles	Wide / Pole(mm)	Current Rating	Fuse Link Matched	Size of Fuse Link
EKF1-32N	1P+N	18	32A	EKFL10	10x38mm
EKF1-32NL					
EKF1-32	1-4P,3P+N	18	32A	EKFL10,EKFL10DC	10x38mm
EKF1-32L					
EKF1-63	1-4P,3P+N	27	63A	EKFL14	14x51mm
EKF1-63L					
EKF1-125	1-4P,3P+N	35	125A	EKFL22	22x58mm
EKF1-125L					

### Overall and Installation Dimension(mm)

EKF1-32

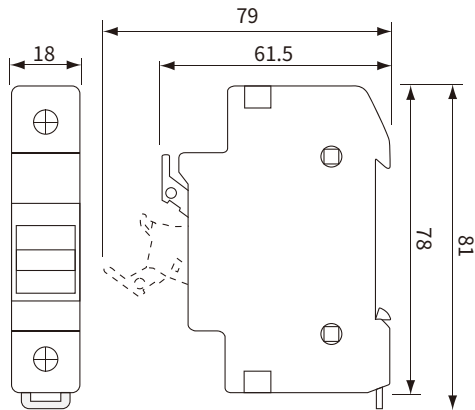

EKF1-63, EKF1-125

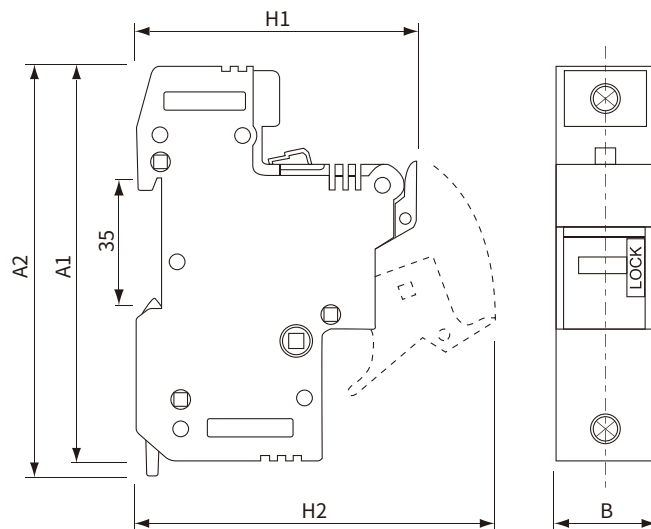





Size	A1	A2	B	H1	H2
EKF1-63	108	111	27	76	100
EKF1-125	127	128	35	77	104

Technical Data

Material	Porcelain,Copper
Rated Voltage Ui	AC 500V,600V
Rated current In	1-125A
Dimensions	10x38,14x51,22x58
Character	gG,aM,oR
Breaking capacity	100kA,120kA

Specifications

Current Rating	Size & Mode No.			
				
	10x38mm	14x51mm	22x58mm	10x38mm(DC)
1A	EKFL1001			EKFL1001DC
2A	EKFL1002			EKFL1002DC
4A	EKFL1004			EKFL1004DC
6A	EKFL1006	EKFL1406		EKFL1006DC
8A	EKFL1008	EKFL1408		EKFL1008DC
10A	EKFL1010	EKFL1410		EKFL1010DC
12A	EKFL1012	EKFL1412		EKFL1012DC
16A	EKFL1016	EKFL1416		EKFL1016DC
20A	EKFL1020	EKFL1420		EKFL1020DC
25A	EKFL1025	EKFL1425	EKFL2225	EKFL1025DC
32A	EKFL1032	EKFL1432	EKFL2232	
40A		EKFL1440	EKFL2240	
50A		EKFL1450	EKFL2250	
63A		EKFL1463	EKFL2263	
80A			EKFL2280	
100A			EKFL22100	
125A			EKFL22125	
Breaking capacity	gG type AC 500V	120kA	120kA	120kA
	aM type AC 500V	100kA	100kA	100kA
	oR type AC 600V	100kA	100kA	100kA
	Gpv type DC 1000V			
Voltage Rating	AC 690V	AC 690	AC 690	DC 1000V
Weight(g)	8.4	20.5	58	10.3



### Impulse Relays

The impulse relays are used to control, by means of pushbuttons, lighting circuits consisting of:

- Incandescent lamps, low-voltage halogen lamps, etc. (resistive loads)
- Fluorescent lamps, discharge lamps, etc. (inductive loads)

### Impulse Relays Are Used

- Closing of the impulse relay pole(s) is triggered by an impulse on the coil.
- Having two stable mechanical positions, the pole(s) will be opened by the next impulse. Each impulse received by the coil reverses the position of the pole(s).
- Can be controlled by an unlimited number of pushbuttons.
- Zero energy consumption.

### Yellow Clip

- A simple clip-on system for flexible auxiliaries combination and improved robustness
- For electrical and mechanical connections
- Insulated terminals IP20
- Built-in or optional auxiliary function: state indication, centralised control, latched control, control for illuminated pushbutton, step-by-step control, time delay
- Manual controls on front face: direct and priority manual control by O-I toggle
- Mechanical contact position indicator
- Disconnection of remote control by selector switch (except for 4P single-piece EKLR16) for maintenance operation

		Choice impulse relays auxiliaries				
Type		Standard EKLR16				
Rating	A	16				
Control voltage	VAC	230/240	130	48	24	45
	VDC	110	48	24	12	6

### Connection

	Type	Rating	Circuit	Tightening torque	Copper cables	
					Rigid or ferrule	Flexible or ferrule
	EKLR16	16 A	Control Power	1 N.m	0.5 to 4 mm <sup>2</sup> 1.5 to 4 mm <sup>2</sup>	1 to 4 mm <sup>2</sup> 1.5 to 4 mm <sup>2</sup>

### Operation

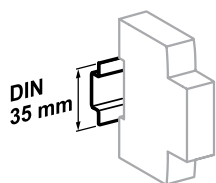
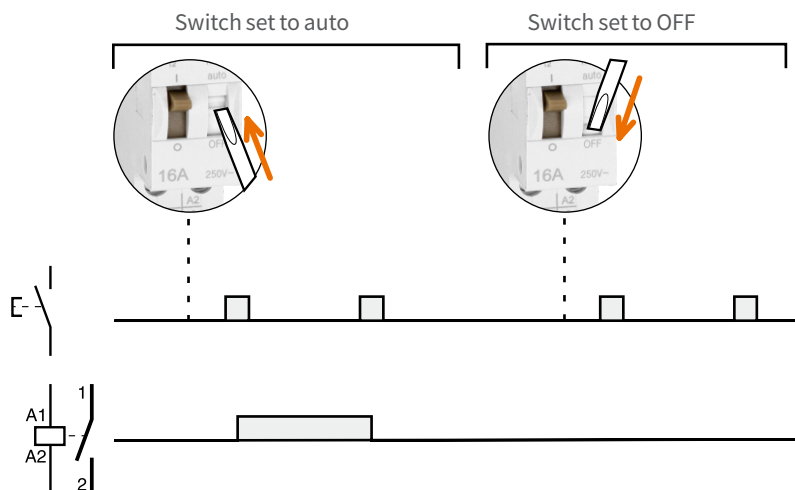

Clip on DIN rail 35 mm.

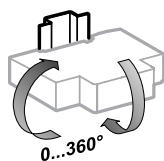

Indifferent position of installation.

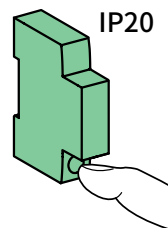

IP20

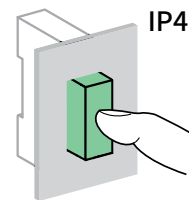

IP40

### Technical Data



Control circuit		
Dissipated power (during the impulse)	1, 2P	19 VA
Illuminated PB control		Max. current 3 mA (if > use an ATLz)
Operating threshold		Min. 85 % of Un in conformance with IEC/EN60669-2-2
Duration of the control order		50 ms to 1 s (200 ms recommended)
Response time		50 ms
Power circuit		
Voltage rating (Ue)	1P, 2P	24 ...250 V AC
Frequency		50 Hz or 60 Hz
Maximum number of operations per minute		5
Maximum number of switching operation a day		100
Additional characteristics to IEC/EN 60947-3		
Insulation voltage (Ui)		440 V AC
Pollution degree		3
Rated impulse withstand voltage (Uimp)		6 kV



### Technical Data

Endurance (O-C)		
Electrical to IEC/EN 60947-3	Device only	200,000 cycles (AC21)
	Device in modular enclosure	100,000 cycles (AC22)
Overvoltage category	IV	
Other characteristics		
Degree of protection (IEC 60529)	Device only	IP20
	Device in modular enclosure	IP40 Insulation class II
Operating temperature	-20°C to +50°C	
Storage temperature	-40°C to +70°C	
Tropicalization (IEC 60068-1)	Treatment 2 (relative humidity 95 % at 55°C)	

### Security

Accessories	Yellow clips	Spacer
		
Function		
	Ensure the mechanical and/or electrical link between impulse relays and their auxiliaries	Required to reduce temperature rise of modular devices installed side by side. Recommended to separate electronic devices (thermostat, programmable clock, etc.) from electromechanical devices (relays, contactors).
Specifications		
Width in 9 mm modules	-	1

### Overall and Installation Dimension(mm)

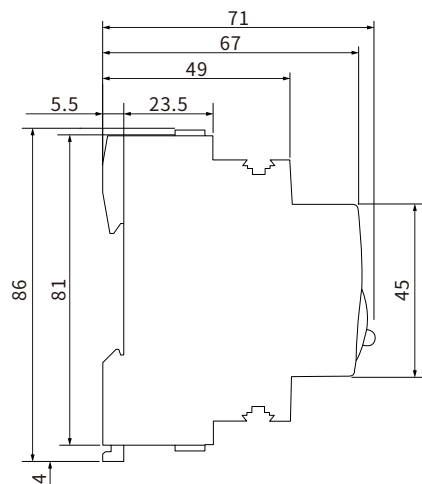
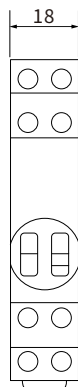



Classification		24 Hours Timer		Timer	Weekly Programmable Timer
Model		EKTM-181H	EKTM-180A	EKTM-E8	EKTM-15A
Appearance					
Contact Capacity		AC250V 16A	AC250V 16A	AC250V 16A	AC250V 16A
Full Timing Range		24h	24h	7m	Per week or per day cycle
Contact resistance		$\leq 50\text{m}\Omega$	$\leq 50\text{m}\Omega$	$\leq 50\text{m}\Omega$	$\leq 50\text{m}\Omega$
Insulation Resistance		$\geq 100\text{m}\Omega$	$\geq 100\text{m}\Omega$	$\geq 100\text{m}\Omega$	$\geq 100\text{m}\Omega$
Coil Voltage		110,230V AC	110,230V AC	110,230V AC	230V AC 85%~110%
Life	Electrical	$10^5$ times	$10^5$ times	$10^5$ times	$10^5$ times
	Mechanical	$10^7$ times	$10^7$ times	$10^7$ times	$10^7$ times
Operating Temperature		-40°C+55°C	-10°C+55°C	-40°C+55°C	-20°C+55°C
Storage Battery (Working Reserve)		Time 150h	Time 70h	—	Rated Voltage: AC200V 50Hz 85%-110% Contact Form:1NC/1NO Accuracy : $\leq 2\text{s/day}(25^\circ\text{C})$ Expectancy Display:LCD Mounting Form: From panel,DIN Rail
Minimum Setting Unit		30Minutes	15Minutes	0.5Minutes	Programmable: 8time week or day Memory Backup:15days
Set up Times		30m/per times 48 times	15m/per times 96 times	1M,1.5M,2M,2.5M 3M,3.5M,4.5M,5M 5.5M,6M,6.5M,7M	



## Description

The Distribution Box is used for Terminal power distributing system

The Distribution Box are completed with Din-rail 35mm and Neutral Terminal

Electrical Rating	100A/single phase,63A/three phase,240/415V AC 50/60Hz
Protection Degree	IP40
Material	Shell: ABS,ABS-UV Fire-proof
	Door: Transparent PC
Method of Installation	Surface-Mounted and Flush-Mounted

## General Type-Full Plastic Surface-Mounted type

Model No.				Ways	Dimension(mm)			Specification of N terminal			Qty/CTN
ABS	Code	ABS-UV	Code		L	W	H	W*H	Screw Qty	Bar Qty	Pcs
EKDB2S2	601101	EKDB2S2V	601201	2	49	130	85				300
EKDB2S3	601102	EKDB2S3V	601202	3	94	148	85				50
EKDB2S4	601103	EKDB2S4V	601203	4	111	200	93	6*8	4	1	30
EKDB2S6	601104	EKDB2S6V	601204	6	148	200	97	6*8	6	2	30
EKDB2S8	601105	EKDB2S8V	601205	8	184	200	96	6*8	8	2	30
EKDB2S10	601106	EKDB2S10V	601206	10	220	200	92	6*8	10	2	20
EKDB2S12	601107	EKDB2S12V	601207	12	254	200	96	6*8	12	2	20
EKDB2S15	601108	EKDB2S15V	601208	15	310	200	97	6*8	15	2	15
EKDB2S18	601109	EKDB2S18V	601209	18	362	219	97	6*8	18	3	10
EKDB2S24	601110	EKDB2S24V	601210	24	271	324	98	6*8	24	4	10
EKDB2S36	601111	EKDB2S36V	601211	36	269	457	100	6*8	36	6	5

## Flush-Mounted type

Model No.				Ways	Dimension(mm)				Specification of N terminal			Qty/CTN
ABS	Code	ABS-UV	Code		L	W	H1	H2	W*H	Screw Qty	Bar Qty	Pcs
EKDB2F2	601121	EKDB2F2V	601221	2	66	137	85	25				200
EKDB2F3	601122	EKDB2F3V	601222	3	94	148	85	26				50
EKDB2F4	601123	EKDB2F4V	601223	4	135	221	87	26	6*8	4	1	30
EKDB2F6	601124	EKDB2F6V	601224	6	171	221	88	26	6*8	6	2	30
EKDB2F8	601125	EKDB2F8V	601225	8	208	221	87	26	6*8	8	2	20
EKDB2F10	601126	EKDB2F10V	601226	10	244	221	86	26	6*8	10	2	20
EKDB2F12	601127	EKDB2F12V	601227	12	280	221	88	24	6*8	12	2	20
EKDB2F15	601128	EKDB2F15V	601228	15	334	221	89	29	6*8	15	2	15
EKDB2F18	601129	EKDB2F18V	601229	18	399	252	86	27	6*8	18	3	10
EKDB2F24	601130	EKDB2F24V	601230	24	300	341	98	31	6*8	24	4	10
EKDB2F36	601131	EKDB2F36V	601231	36	300	480	98	31	6*8	36	6	5

**Double Rows Terminal type-Full Plastic (Australia Type)**  
**Surface-Mounted type**

Model No.				Ways	Dimension(mm)			Specification of N terminal			Qty/CTN
ABS	Code	ABS-UV	Code		L	W	H	W*H	Screw Qty	Bar Qty	Pcs
EKDB2S4T2	601303	EKDB2S4VT2	601403	4	111	200	93	10*14	8	1	30
EKDB2S6T2	601304	EKDB2S6VT2	601404	6	148	200	97	10*14	12	2	30
EKDB2S8T2	601305	EKDB2S8VT2	601405	8	184	200	96	10*14	16	2	30
EKDB2S10T2	601306	EKDB2S10VT2	601406	10	220	200	92	10*14	20	2	20
EKDB2S12T2	601307	EKDB2S12VT2	601407	12	254	200	96	10*14	24	2	20
EKDB2S15T2	601308	EKDB2S15VT2	601408	15	310	200	97	10*14	30	2	15
EKDB2S18T2	601309	EKDB2S18VT2	601409	18	362	219	97	10*14	36	3	10
EKDB2S24T2	601310	EKDB2S24VT2	601410	24	271	324	98	10*14	48	4	10
EKDB2S36T2	601311	EKDB2S36VT2	601411	36	269	457	100	10*14	72	6	5

**Flush-Mounted type**

Model No.				Ways	Dimension(mm)				Specification of N terminal			Qty/CTN
ABS	Code	ABS-UV	Code		L	W	H1	H2	W*H	Screw Qty	Bar Qty	Pcs
EKDB2F4T2	601323	EKDB2F4VT2	601423	4	135	221	87	26	10*14	8	1	30
EKDB2F6T2	601324	EKDB2F6VT2	601424	6	171	221	88	26	10*14	12	2	30
EKDB2F8T2	601325	EKDB2F8VT2	601425	8	208	221	87	26	10*14	16	2	20
EKDB2F10T2	601326	EKDB2F10VT2	601426	10	244	221	86	26	10*14	20	2	20
EKDB2F12T2	601327	EKDB2F12VT2	601427	12	280	221	88	24	10*14	24	2	20
EKDB2F15T2	601328	EKDB2F15VT2	601428	15	334	221	89	29	10*14	30	2	15
EKDB2F18T2	601329	EKDB2F18VT2	601429	18	399	252	86	27	10*14	36	3	10
EKDB2F24T2	601330	EKDB2F24VT2	601430	24	300	341	98	31	10*14	48	4	10
EKDB2F36T2	601331	EKDB2F36VT2	601431	36	300	480	98	31	10*14	72	6	5

**Overall and Installation Dimension(mm)**

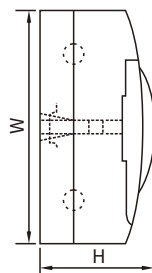
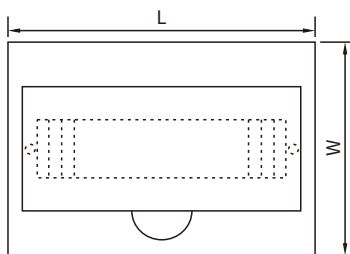

Surface-Mounted type

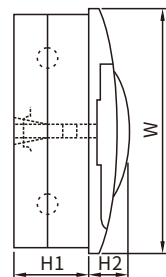

Flush-Mounted type



### Description

The Distribution Box is used for Terminal power distributing system

The Distribution Box are completed with Din-rail 35mm and Neutral Terminal (Selectable)

Electrical Rating	100A/single phase,63A/three phase,240/415V AC 50/60Hz
Protection Degree	IP65
Material	Shell: ABS
	Door: Transparent PC
Method of Installation	Surface-Mounted

### Type of open door from right to left Without Neutral Terminal Model

Model No.		Ways	Dimension(mm)			Qty/CTN
PC	Code		L	W	H	Pcs
EKDB4P4R	604241	4	231	166	113	30
EKDB4P6R	604242	6	231	202	113	20
EKDB4P8R	604243	8	231	238	118	20
EKDB4P9R	604244	9	219	200	102	20
EKDB4P12R	604245	12	246	310	148	20
EKDB4P18R	604246	18	286	418	148	20
EKDB4P24R	604247	24	436	310	148	10

### With Neutral Terminal Model

Model No.		Ways	Dimension(mm)			Qty/CTN
PC	Code		L	W	H	Pcs
EKDB4P4RT	604211	4	231	166	113	30
EKDB4P6RT	604212	6	231	202	113	20
EKDB4P8RT	604213	8	231	238	118	20
EKDB4P9RT	604214	9	219	200	102	20
EKDB4P12RT	604215	12	246	310	148	20
EKDB4P18RT	604216	18	286	418	148	20
EKDB4P24RT	604217	24	436	310	148	10

### Overall and Installation Dimension(mm)

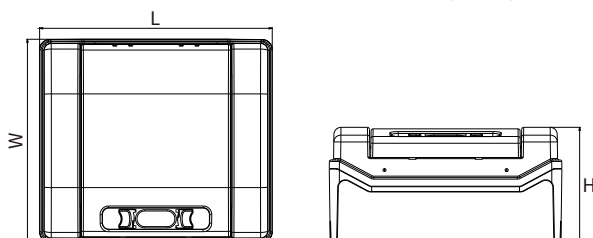



### Description

The Distribution Box is used for Terminal power distributing system  
The Distribution Box are completed with Din-rail 35mm and Neutral Terminal (Selectable)

Electrical Rating	100A/single phase,240/415V AC 50/60Hz
Protection Degree	IP40
Material	Steel
Method of Installation	Surface-Mounted

### Empty Box

#### With Neutral and Earth Terminal

Model No.		Ways	Dimension(mm)						Qty/CTN	
Model	Code		H	W	D	D1	W1	H1	Pcs	
EKDB6S6	606221	6	258.6	160	109	87	156	255	6	
EKDB6S10	606222	10	258.6	232	109	87	228	255	6	
EKDB6S14	606223	14	258.6	304	109	87	300	255	4	
EKDB6S18	606224	18	258.6	376	109	87	372	255	4	
EKDB6S24	606225	24	258.6	484	109	87	480	255	4	

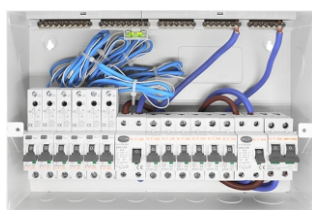
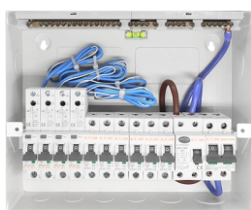

#### Complete set of Distribution Box with Busbar, Neutral and Earth Terminals , Cables Connected

Reference No.	Size of Box	Description	Free ways	MCB Selected by user	RCBO Selected by user
EKDB6S6-IS	6WAYS	DB Box with 1x2P 100A Isolator	4	MCB 1P 6KA, type B or type C, Rated Current: 6A,10A,16A,20A,25 A,32A,40A	RCBO 1P+N 6KA, type B or type C, IΔn: 30mA Rated Current: 6A,10A,16A,20A,25 A,32A,40A
EKDB6S6-RCD	6WAYS	DB Box with 1x2P 80A RCD	4		
EKDB6S10-IS-RCD	10WAYS	DB Box with 1x2P 100A Isolator + 1x2P 80A RCD	6		
EKDB6S10-IS	10WAYS	DB Box with 1x2P 100A Isolator	8		
EKDB6S10-RCD	10WAYS	DB Box with 1x2P 80A RCD	8		
EKDB6S14-IS-RCD	14WAYS	DB Box with 1x2P 100A Isolator + 1x2P 80A RCD	10		
EKDB6S14-IS-RCD2	14WAYS	DB Box with 1x2P 100A Isolator + 2x2P 80A RCD	4+4		
EKDB6S18-IS-RCD	18WAYS	DB Box with 1x2P 100A Isolator + 1x2P 80A RCD	14		
EKDB6S18-IS-RCD2	18WAYS	DB Box with 1x2P 100A Isolator + 2x2P 80A RCD	6+6		
EKDB6S24-IS-RCD2	24WAYS	DB Box with 1x2P 100A Isolator + 2x2P 80A RCD	9+9		

#### Overall and Installation Dimension(mm)

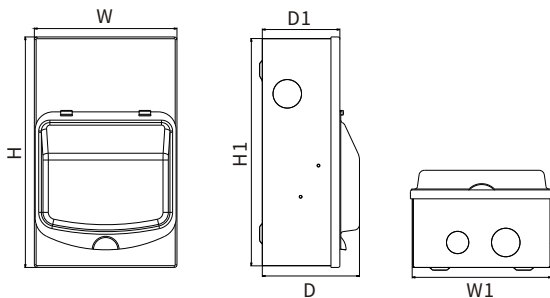



### Description

The Distribution Box is used for Terminal power distributing system

The Distribution Box are completed with Din-rail 35mm and Neutral Terminal (Selectable)

Electrical Rating 125A single phase/three phase,240/415V AC 50/60Hz

Protection Degree IP40,IP65

Material Steel

Method of Installation Surface-Mounted and Flush-Mounted

### MCB Type

Model No.		Ways	Dimension(mm)			Qty/CTN	
Model	Row		Code	H	W	D	Pcs
EKDB7113	1	616001	13	355	275	110	1
EKDB7226	2	616002	26	355	380	110	1
EKDB7339	3	616003	39	355	530	110	1
EKDB7452	4	616004	52	355	680	110	1
EKDB7565	5	616005	65	355	930	110	1
EKDB7118	1	616101	18	475	275	110	1
EKDB7236	2	616102	36	475	380	110	1
EKDB7354	3	616103	54	475	530	110	1
EKDB7472	4	616104	72	475	680	110	1
EKDB7690	5	616105	90	475	830	110	1
EKDB7122	1	616201	22	547	275	110	1
EKDB7244	2	616202	44	547	380	110	1
EKDB7366	3	616203	66	547	530	110	1
EKDB7488	4	616204	88	547	680	110	1
EKDB75110	5	616205	110	547	830	110	1

### Overall and Installation Dimension(mm)

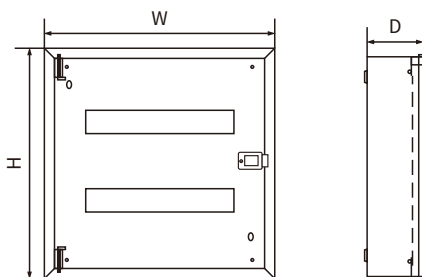



### Description

The Distribution Box is used for Terminal power distributing system	
The Distribution Box are completed with Din-rail 35mm and Neutral Terminal (Selectable)	
Electrical Rating	250A three phase,240/415V AC 50/60Hz
Protection Degree	IP40,IP65
Material	Steel
Method of Installation	Surface-Mounted and Flush-Mounted

### MCCB Type

Model No.		Ways	Dimension(mm)			Qty/CTN	
Model	Row		Code	H	W	D	Pcs
EKDB7113-1	1	616301	13	360	325	110	1
EKDB7226-1	2	616302	26	360	430	110	1
EKDB7339-1	3	616303	39	360	580	110	1
EKDB7452-1	4	616304	52	360	730	110	1
EKDB7565-1	5	616305	65	360	880	110	1
EKDB7118-1	1	616401	18	480	325	110	1
EKDB7236-1	2	616402	36	480	430	110	1
EKDB7354-1	3	616403	54	480	580	110	1
EKDB7472-1	4	616404	72	480	730	110	1
EKDB7690-1	5	616405	90	480	880	110	1
EKDB7122-1	1	616501	22	550	325	110	1
EKDB7244-1	2	616502	44	550	430	110	1
EKDB7366-1	3	616503	66	550	580	110	1
EKDB7488-1	4	616504	88	550	730	110	1
EKDB75110-1	5	616505	110	550	880	110	1

### Overall and Installation Dimension(mm)

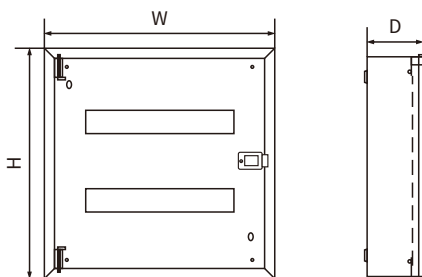





### Description

The Distribution Box is used for Terminal power distributing system

Electrical Rating 100A/single phase,240/415V AC 50/60Hz

Protection Degree IP65

Material Steel

Method of Installation Surface-Mounted

### Main technique parameter

Model No.		Size(mm)			Thickness(mm)			Bottom hole size	Lock QTY	Mounting plate size(mm)	
Model	Code	H	W	D	Door	Body	M.P			L	M
EKDB8 2020/15	610001	200	200	150	1.2	1.2	2	A	1	150	150
EKDB8 2520/15	610002	250	200	150	1.2	1.2	2	A	1	250	150
EKDB8 3020/15	610003	300	200	150	1.2	1.2	2	A	1	250	150
EKDB8 3020/20	610004	300	200	200	1.2	1.2	2	A	1	250	150
EKDB8 3025/15	610005	300	250	150	1.2	1.2	2	A	1	250	200
EKDB8 3025/20	610006	300	250	200	1.2	1.2	2	A	1	250	200
EKDB8 3030/15	610007	300	300	150	1.2	1.2	2	B	1	250	250
EKDB8 3030/20	610008	300	300	200	1.2	1.2	2	B	1	250	250
EKDB8 3030/25	610009	300	300	250	1.2	1.2	2	B	1	250	250
EKDB8 4030/15	610010	400	300	150	1.2	1.2	2	B	1	350	250
EKDB8 4030/20	610011	400	300	200	1.2	1.2	2	B	1	350	250
EKDB8 4030/25	610012	400	300	250	1.2	1.2	2	B	1	350	250
EKDB8 4030/30	610013	400	300	300	1.2	1.2	2	B	1	350	250
EKDB8 4040/15	610014	400	400	150	1.2	1.2	2	C	1	350	250
EKDB8 4040/20	610015	400	400	200	1.2	1.2	2	C	1	350	350
EKDB8 4040/25	610016	400	400	250	1.2	1.2	2	C	1	350	350
EKDB8 4040/30	610017	400	400	300	1.2	1.2	2	C	1	350	350
EKDB8 5030/15	610018	500	300	150	1.2	1.2	2	B	1	450	350
EKDB8 5030/20	610019	500	300	200	1.2	1.2	2	B	1	450	250
EKDB8 5030/25	610020	500	300	250	1.2	1.2	2	B	1	450	250
EKDB8 5040/15	610021	500	400	150	1.2	1.2	2	C	1	450	350
EKDB8 5040/20	610022	500	400	200	1.2	1.2	2	C	1	450	350
EKDB8 5040/25	610023	500	400	250	1.2	1.2	2	C	1	450	350
EKDB8 5040/30	610024	500	400	300	1.2	1.2	2	C	1	450	350
EKDB8 5050/20	610025	500	500	200	1.2	1.2	2	D	1	450	450
EKDB8 5050/25	610026	500	500	250	1.2	1.2	2	D	1	450	450
EKDB8 5050/30	610027	500	500	300	1.2	1.2	2	D	1	450	450
EKDB8 6040/15	610028	600	400	150	1.2	1.2	2	C	2	550	350
EKDB8 6040/20	610029	600	400	200	1.2	1.2	2	C	2	550	350
EKDB8 6040/25	610030	600	400	250	1.2	1.2	2	C	2	550	350
EKDB8 6040/30	610031	600	400	300	1.2	1.2	2	C	2	550	350
EKDB8 6050/15	610032	600	500	150	1.2	1.2	2	D	2	550	450
EKDB8 6050/20	610033	600	500	200	1.2	1.2	2	D	2	550	450
EKDB8 6050/25	610034	600	500	250	1.2	1.2	2	D	2	550	450
EKDB8 6050/30	610035	600	500	300	1.2	1.2	2	D	2	550	450
EKDB8 6060/15	610036	600	600	150	1.2	1.2	2	D	2	550	550
EKDB8 6060/20	610037	600	600	200	1.2	1.2	2	D	2	550	550
EKDB8 6060/25	610038	600	600	250	1.2	1.2	2	D	2	550	550
EKDB8 6060/30	610039	600	600	300	1.2	1.2	2	D	2	550	550

Main technique parameter

Model No.		Size(mm)			Thickness(mm)			Bottom hole size	Lock QTY	Mounting plate size(mm)	
Model	Code	H	W	D	Door	Body	M.P			L	M
EKDB8 7050/15	610040	700	500	150	1.2	1.2	2	D	2	650	450
EKDB8 7050/20	610041	700	500	200	1.2	1.2	2	D	2	650	450
EKDB8 7050/25	610042	700	500	250	1.2	1.2	2	D	2	650	450
EKDB8 7060/20	610043	700	600	200	1.2	1.2	2	D	2	650	550
EKDB8 7060/25	610044	700	600	250	1.2	1.2	2	D	2	650	550
EKDB8 7060/30	610045	700	600	300	1.5	1.5	2	D	2	650	550
EKDB8 8060/20	610046	800	600	200	1.5	1.5	2	D	2	750	550
EKDB8 8060/25	610047	800	600	250	1.5	1.5	2	D	2	750	550
EKDB8 8060/30	610048	800	600	300	1.5	1.5	2	D	2	750	550
EKDB8 8080/20	610049	800	800	200	1.5	1.5	2	F	2	750	750
EKDB8 8080/25	610050	800	800	250	1.5	1.5	2	F	2	750	750
EKDB8 8080/30	610051	800	800	300	1.5	1.5	2	F	2	750	750
EKDB8 10060/20	610052	1000	600	200	1.5	1.5	2	D	2	950	550
EKDB8 10060/25	610053	1000	600	250	1.5	1.5	2	D	3	950	550
EKDB8 10060/30	610054	1000	600	300	1.5	1.5	2	D	3	950	550
EKDB8 10070/20	610055	1000	700	200	1.5	1.5	2	D	3	950	650
EKDB8 10080/20	610056	1000	800	200	1.5	1.5	2	F	3	950	750
EKDB8 10080/25	610057	1000	800	250	1.5	1.5	2	F	3	950	750
EKDB8 10080/30	610058	1000	800	300	1.5	1.5	2	F	3	950	750
EKDB8 10080/40	610059	1000	800	400	1.5	1.5	2	F	3	950	750
EKDB8 100100/25	610060	1000	1000	250	1.5	1.5	2	G	3	950	950
EKDB8 100100/30	610061	1000	1000	300	1.5	1.5	2	G	3	950	950
EKDB8 12060/20	610062	1200	600	200	1.5	1.5	2	D	3	1150	550
EKDB8 12060/25	610063	1200	600	250	1.5	1.5	2	D	3	1150	550
EKDB8 12060/30	610064	1200	600	300	1.5	1.5	2	D	3	1150	550
EKDB8 12080/20	610065	1200	800	200	1.5	1.5	2	F	3	1150	750
EKDB8 12080/25	610066	1200	800	250	1.5	1.5	2	F	3	1150	750
EKDB8 12080/30	610067	1200	800	300	1.5	1.5	2	F	3	1150	750
EKDB8 12080/40	610068	1200	800	400	1.5	1.5	2	F	3	1150	750
EKDB8 120100/25	610069	1200	1000	250	1.5	1.5	2	G	3	1150	750
EKDB8 120100/30	610070	1200	1000	300	1.5	1.5	2	G	3	1150	950
EKDB8 120100/40	610071	1200	1000	400	1.5	1.5	2	G	3	1150	950
EKDB8 14060/30	610072	1400	600	300	1.5	1.5	2	D	3	1350	550
EKDB8 14080/30	610073	1400	800	300	1.5	1.5	2	F	3	1350	750
EKDB8 14080/40	610074	1400	800	400	1.5	1.5	2	F	3	1350	750
EKDB8 140100/30	610075	1400	1000	300	1.5	1.5	2	G	3	1350	950
EKDB8 140120/30	610076	1400	1200	300	1.5	1.5	2	G	3	1350	1150

Overall and Installation Dimension(mm)

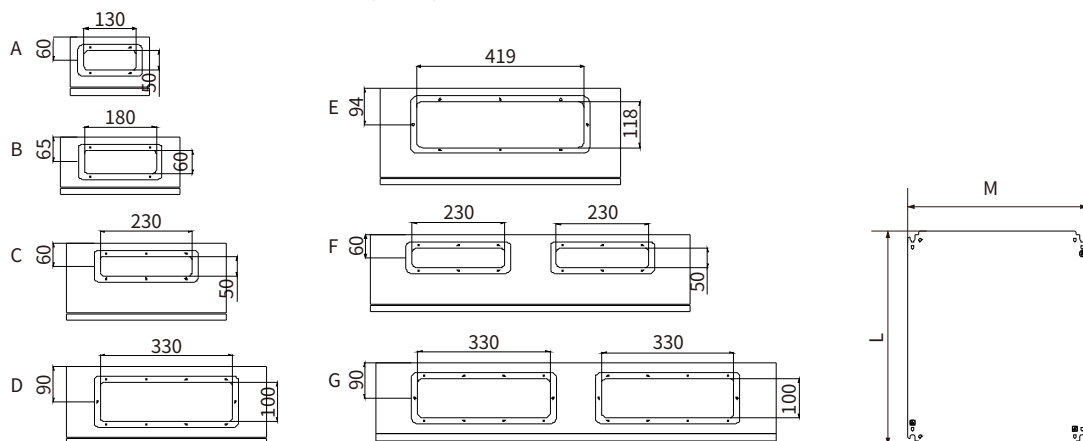

## ▶ CERTIFICATE ◀

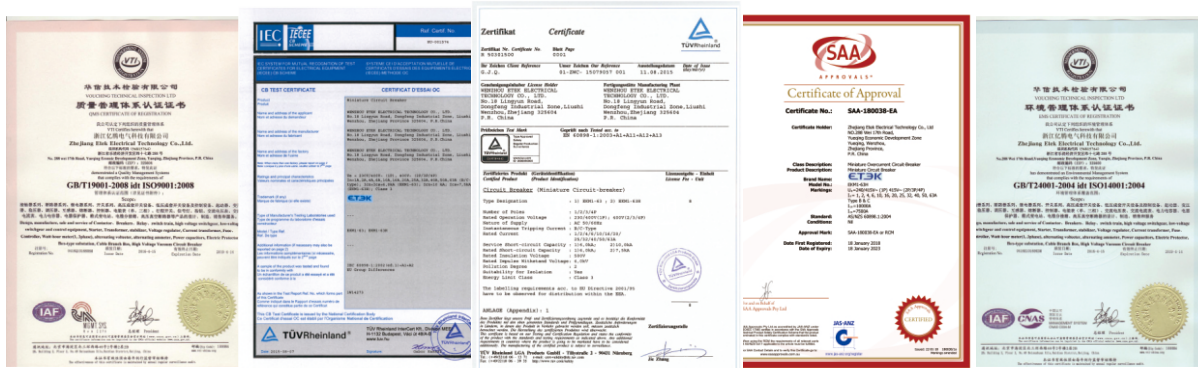

## ▶ PACKAGING ◀



## ▶ SHIPPING ◀

